

CARAN D'ACHE

Genève

Writing Instruments
& Accessories

2018





LA MAISON CARAN D'ACHE

FROM AN ARTIST'S SIGNATURE TO THE ART OF BEAUTIFUL WRITING

In that area of emotions where writing and images fuse together, the grace of a curving line, the energy in the stroke of a pen and the depth of a rich colour are among the elements that led Caran d'Ache to develop its passion for fine writing. Since 1915, steeped in the great traditions of Swiss Manufacturing, the company has created writing instruments, and a palette of colours, that are universally recognised symbols of excellence.

These reliable, precise and precious objects have acquired an international reputation for combining creativity and distinction with the use of noble materials.

To continue this policy, our Geneva workshops carefully preserve their independent spirit and their commitment to authenticity and ethical production.

MANUFACTURED IN GENEVA WORKSHOPS

Caran d'Ache draws on a priceless heritage of technical expertise to preserve the art of handwriting. The company's writing instruments, globally recognised for their excellence, are entirely produced in Geneva. In the secret of their workshops, Caran d'Ache craftsmen boldly combine expertise and aesthetics in the great Swiss Made tradition. To create these emotive objects, which are also feats of technology, they offer original materials and perfect forms, giving writing an innate sense of refinement.

CARAN D'ACHE, IN LOVE WITH COLOUR

The play of light on the material... its soft, velvety texture... the precious pigments brought from mysterious places... There has been a genuine love of colours, and the traditions of manufacturing them, in our Geneva workshops ever since our first pencil was produced nearby in 1915.

The fine, smooth leads, the subtly transparent watercolours and the brilliant, deep, light-resistant paints have been developed for creative professionals as well as amateur artists. They all reflect Caran d'Ache's exceptional Swiss Made quality and love of its craft.

As a Maison de Haute Ecriture, we respect nature as well as people. The premium-quality cedar used in our pencils is certified FSC, and our production of leads, pastels and paints carefully follows the principles of sustainable development.





THE ART OF BEAUTIFUL WRITING

Just as the art of writing brings together characters, gestures and traditions, Caran d'Ache writing instruments represent refinement, creativity and expertise, all expressed with Swiss Made excellence.

For a century, Caran d'Ache collections have reflected the passion and the subtlety of fine writing. They are jewels of technology with inspired designs; emblems of excellence enhanced by rare and noble materials.

Lacquered, guilloched or polished bodies feel superb in the hand; rhodium-coated nibs or long-life tungsten ballpoints provide a great writing touch; contemporary or classic designs create a seductive visual appeal. Caran d'Ache writing instruments are treasures for all those who appreciate genuine distinction.

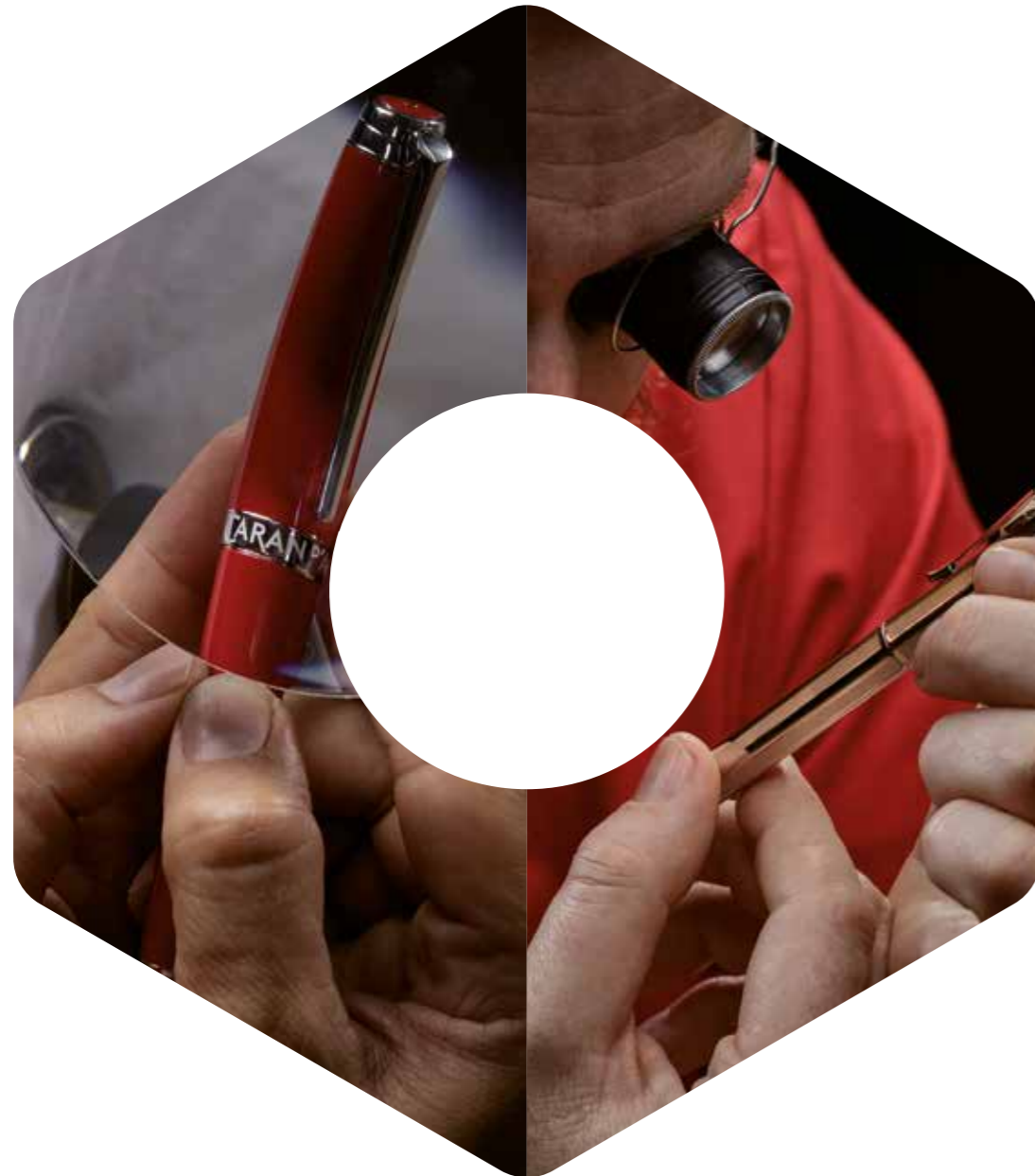

EXPERTISE

THE ARTISTIC CRAFTS

ENGRAVING

The fine engraving that characterises Caran d'Ache writing instruments is the product of patient, meticulous work. The company's innovative techniques of milling and engraving with lasers or diamonds make it possible to produce a large variety of outlines and reliefs that bring a design to life by creating a delicate play of light and shadow. Whether it is guillochage or personalised engraving, each piece receives the same attention to detail, making the finished instrument a treasure of refinement.

POLISHING

A soft touch, comfortable writing and perfect design... sometimes sparkling, sometimes matt, each part of these Caran d'Ache products is carefully worked. All the writing instruments finished in precious materials are polished, which is also a very important operation when applying lacquer or Chinese lacquer.

THE UNIQUE EXPERTISE OF THE LACQUER MASTER

A finish that requires exceptional precision, lacquer gloriously enhances a writing instrument with an incomparable brilliance and its large palette of tints that Caran d'Ache is constantly extending. Because preparing and applying lacquer requires such extraordinary skill, the work of the lacquer master is uniquely valuable. It demonstrates the company's commitment to authenticity and excellence in every product it creates.

JEWELLERY

Setting diamonds, rubies, sapphires, emeralds, and engraving initials, a name, or even a short message... Caran d'Ache offers all lovers of rare objects the possibility of personalising their writing instrument. If they wish, they can choose the precious stones which will then be set by a Geneva jeweller. Each personalised writing instrument is numbered, engraved and accompanied by a certificate. Gemstones used by Caran d'Ache are from controlled, ethical sources, are not involved in the financing of armed conflicts and conform to United Nations resolutions.

NOBLE MATERIALS

PRECIOUS METALS: SILVER, RHODIUM, PLATINUM, PALLADIUM

Caran d'Ache creations in silver or solid gold are systematically controlled by the Federal Office of Metals and are certified with its seal. Gold is the metal used in the most beautiful work produced by Caran d'Ache craftsmen. Like real goldsmiths, they sculpt it, decorate it, engrave it and polish it.

But Caran d'Ache also explores other horizons with rhodium, the metal in the platinum family whose hardness and rarity make it twice as expensive as gold. Extremely strong, it enables writing instruments to keep their brilliance over the years, protecting them from corrosion and rust, as well as abrasion and tarnishing. Rare, pure and inert, rhodium is the most exclusive of the precious metals used by the company.

CHINESE LACQUER

A natural, living product derived from the sap of the Rhus Verniciflua tree, Chinese lacquer regularly inspires the most beautiful Caran d'Ache creations. Using traditional expertise inherited from the great oriental masters, the company is one of the very few in the world to have the secret... and the patience. The multiple coats of lacquer are applied over a period of twelve days. Chinese lacquer, which may be natural colour or tinted with pigments of blue, black or red, embellishes lighters and writing instruments in the Varius collections as well as the Limited editions.



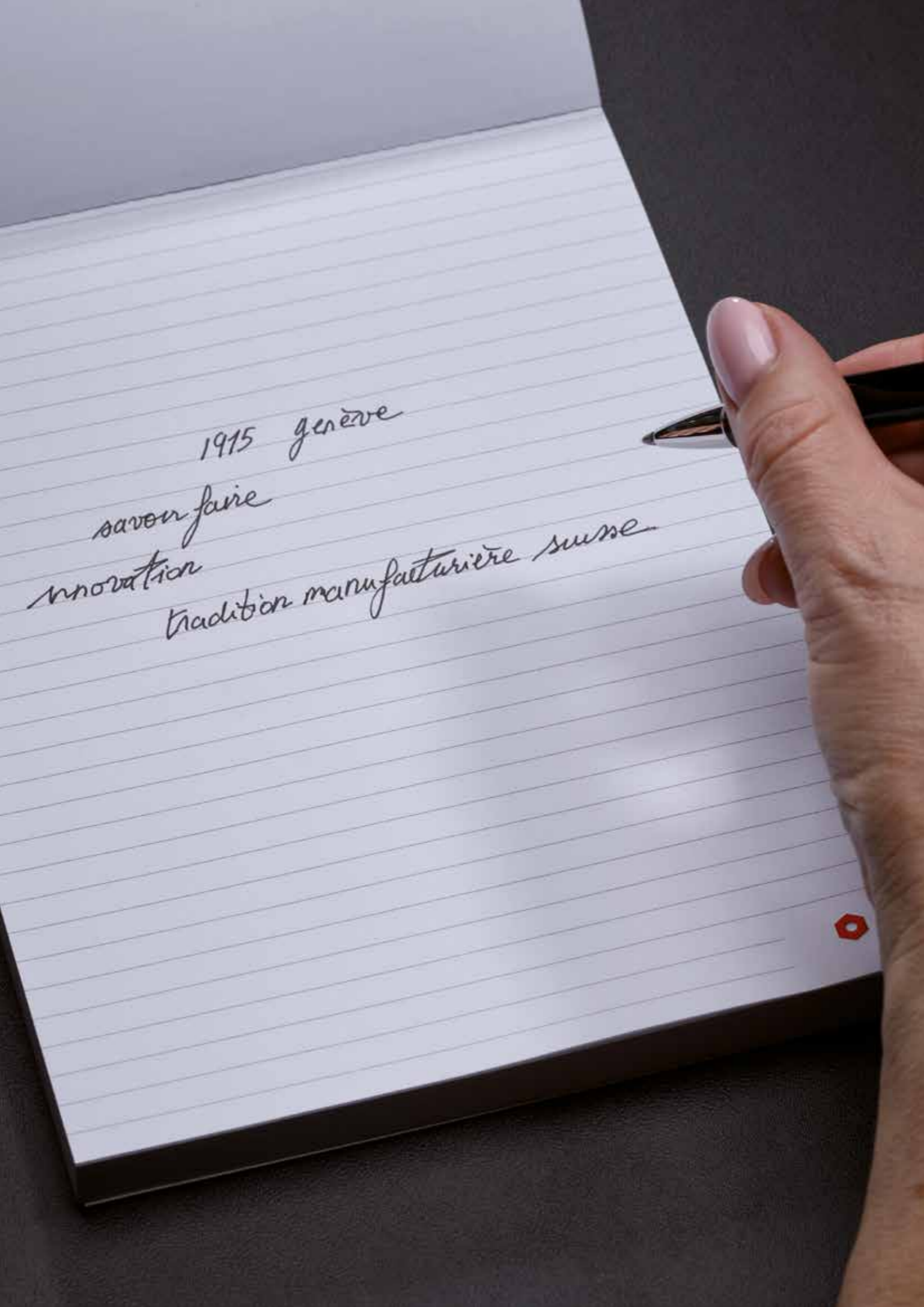

CARAN D'ACHE

LA MAISON CARAN D'ACHE	3
THE ART OF BEAUTIFUL WRITING	5
EXPERTISE	7

LIMITED EDITIONS

PRESTIGE	<i>Astrograph</i>	13
	<i>Caelograph</i>	19
SPECIAL	<i>Justice League</i>	27
	<i>Varius Peter Marino</i>	37
HOMMAGE	<i>Oberalp</i>	45
	<i>Spirit of Switzerland</i>	49
	<i>Chinese Zodiac</i>	53

COLLECTIONS

VARIUS	63
LÉMAN & LÉMAN SLIM	81
RNX.316	103
ECRIDOR	111
THE PENCILS OF LA MAISON CARAN D'ACHE	137

WRITING ACCESSORIES

CHROMATICS	<i>Ink bottle</i>	145
	<i>Ink cartridges</i>	147
REFILLS	149	

ACCESSORIES

LEATHER	<i>Haute Maroquinerie</i>	153
	<i>Leman</i>	159
BELTS	169	
CUFFLINKS	171	

SERVICES

FOUNTAIN PEN NIBS	174
PERSONALISED ENGRAVING	175
INTERNATIONAL GUARENTEE	176
CORPORATE GIFTS	177
PACKAGING	177
THE MERCHANDISING AT CARAN D'ACHE	178



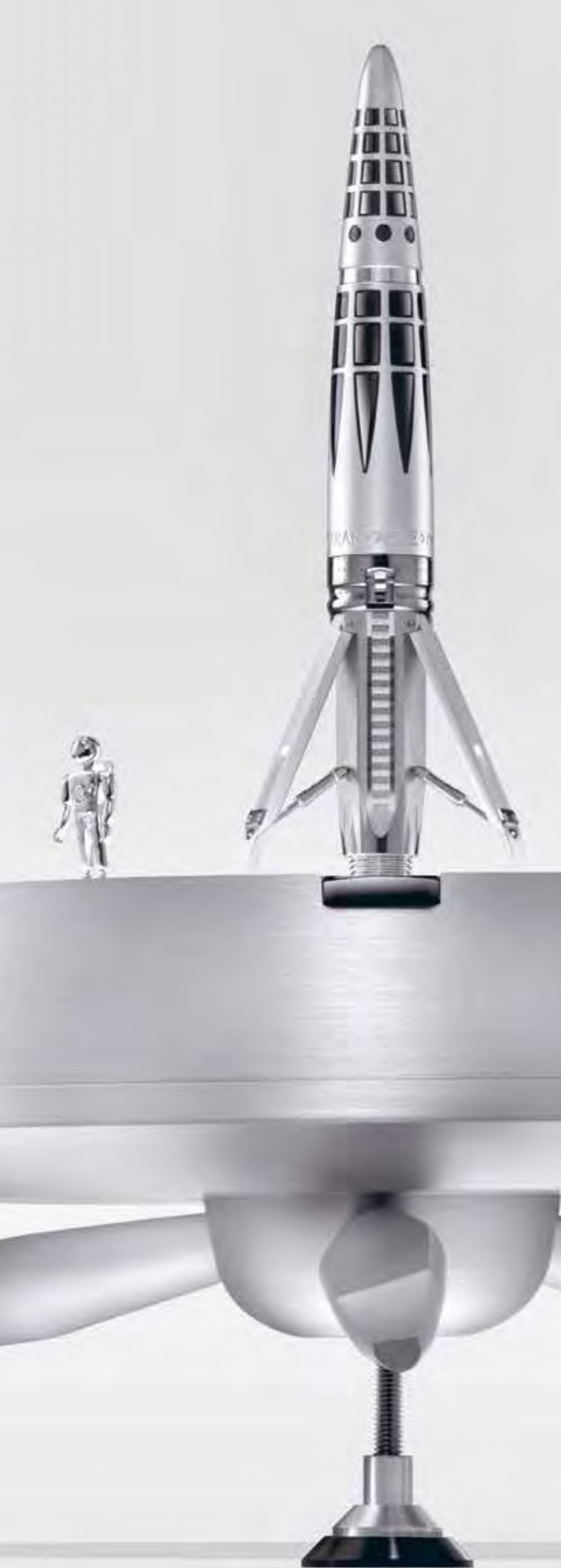

PRESTIGE

LIMITED EDITIONS



ASTROGRAPH

The Maison Caran d'Ache and the horological laboratory MB&F, have combined their expertise for a unique creative odyssey: the Astrograph writing instrument.

Bound by a shared creative passion for mechanical excellence, the Maison Caran d'Ache and the youthful watch Maison MB&F have combined their expertise in developing the exceptional Astrograph writing instrument. This new creation pays tribute to the exploratory genius and childhood dreams that spark technical feats.

Conquering new territory

Propelling one's own dreams into space by means of a rocket-pen: such was the original idea dreamt up by Maximilian Büsser – a new adventure that has been enthusiastically welcomed by the creative and technical teams at Maison Caran d'Ache. With the Astrograph, Caran d'Ache and MB&F have developed an instrument featuring complex architecture while ensuring perfect writing comfort. Like a modern-day odyssey, the creation of this exceptional model symbolises the conquest of space through making dreams come true.





Creating the Astrograph was an authentic technical challenge to which the Maison Caran d'Ache teams rose with aplomb. Fine-tuning the concept called for four years of gestation and fruitful exchanges, while an entire year was devoted to developing the final model. More than 500 manual operations were involved in its production in the workshops of the Geneva-based Manufacture. Astrograph features a slim body evoking the outlines of a space vessel. The perfectly integrated design of this creation comprises 99 innovative elements. Astrograph comes in three finishes: high-gloss rhodium, sandblasted matt rhodium or anthracite ruthenium, issued in a numbered 99-piece edition per finish. The generic numbering is engraved on one of the three stabiliser feet: « Limited editions 1 in 99 pieces ».



ASTROGRAPH
HIGH GLOSS RHODIUM FINISH

FOUNTAIN PEN / M nib - 1654.481 (other nib widths available on request)

18 carats gold nib, rhodium-coated
Limited editions in 99 fountain pen
Refills: Ink and cartridges Chromatics Collection (p. 140 - 143)



ASTROGRAPH
RUTHENIUM FINISH

FOUNTAIN PEN / M nib - 1656.481 (other nib widths available on request)

18 carats gold nib, rhodium-coated
Limited editions in 99 fountain pen
Refills: Ink and cartridges Chromatics Collection (p. 140 - 143)



ASTROGRAPH
RHODIUM, SANDBLASTED MATT FINISH

FOUNTAIN PEN / M nib - 1655.481 (other nib widths available on request)

18 carats gold nib, rhodium-coated
Limited editions in 99 fountain pen
Refills: Ink and cartridges Chromatics Collection (p. 140 - 143))



ASTROGRAPH
RHODIUM, SANDBLASTED MATT FINISH

ROLLER PEN / 1665.481

Limited editions in 99 fountain pen.
Refills: Roller cartridge, fine or medium, blue or black (p. 144)





Featuring a launch pad-style design, the Astrograph case accommodates both the rocket-pen and its accompanying astronaut, ready to head for the stars. Aluminium case, designed with a coloured-launch pad drawing. Plexiglas lid, magnetic closing system. 3 holes of anchoring are placed on top of the lid to fix the rocket in the lid's centre.

DELIVERED WITH THE ASTROGRAPH LIMITED EDITIONS:

- owner's guide book and guarantee
- two small ink cartridges or roller pen cartridge (F black)
- Astrograph leather pouch
- Astrograph brochure



THE BOX
ASTROGRAPH

Dimensions / 342 x 385 x 145 mm
 Height with closed-lid: 100 mm
 Height with open-lid: 300 mm
 Height with close-lid + standing rocket: 265 mm
 Top diameter: 200 mm
 Total diameter (on floor): 440 mm
 This case can also be used as a display base for window-front shops or display stands.

THE POUCH
ASTROGRAPH

Dimensions of the shield pouch closed:
 180 x 60 x 25 mm
 Made in cow smooth leather in black, leaning in nubuck and magnetic closing system

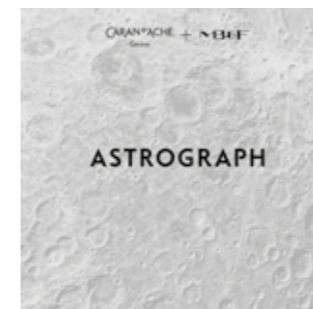

THE BROCHURE
ASTROGRAPH

24.5 x 24.5 cm
 20 interior pages
 Trilingual brochure: FR/ DE/ EN
 Reference: 100015.697





CAELOGRAPH

Caran d'Ache unveils a unique fine writing instrument, the Caelograph, that combines technical expertise with design in exploring one of man's most fascinating passions: the sky. In its long tradition of innovation, Caran d'Ache has developed another exceptional writing instrument that demonstrates great creativity and expertise. Like inventors always searching for new solutions, the craftsmen at Caran d'Ache have worked closely with an astronomer to produce this unique instrument that explores the sky and the stars.

A personalised journey deep into the cosmos

Is it a writing instrument? A sky-watching tool? A work of art? The Caelograph is all of these. With a name that literally means "Write the sky" its ingenious mechanism allows you to see the position of the stars and the constellations at any given time, on any date. It brings alive the close, mystical relationship that has existed between man and the stars, Earth and sky, since the dawn of time.

As an instrument for writing and for observation, the Caelograph symbolises the union of arts and science, of man and the stars. Produced in three limited series, it is a compelling tribute to astronomy. The Caelograph features a chart of the sky that is delicately engraved on night blue Chinese lacquer impregnated with silver particles. The grooves on the cap and the writing block are the hour lines typically found on sun dials. The pen's tip is embellished with a compass rose while the clip takes the form of a compass needle, evoking the ageless link between navigation and astronomy.

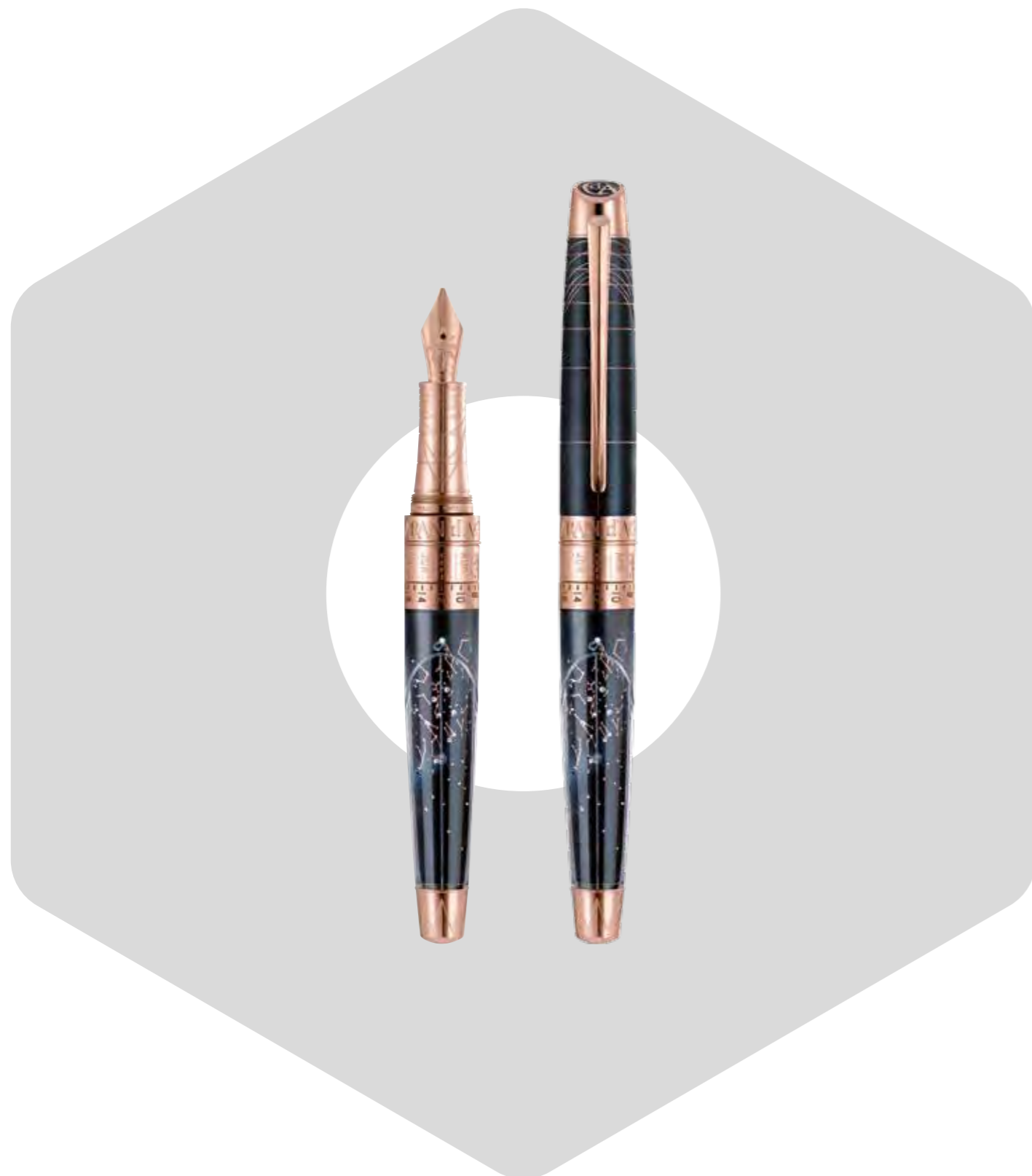

THE MECHANICS OF THE SKY IN YOUR HAND

With great technical expertise, this exclusive invention presents a map of the sky in a design enhanced by midnight blue Chinese lacquer. Apart from the natural requirement for accuracy, reproducing a flat map on the curved surface of a pen is a serious technical challenge. For the first time, the projection process known as Mercator has been applied to a writing instrument. In a second technical feat, Caran d'Ache has managed to represent, on a surface as small as the pen body, the 51 constellations and 353 stars visible from the northern hemisphere. And that is not all it does. The sky chart is mobile in order to indicate the position of the stars at any chosen time. This astonishing capability is made possible by an exclusive, highly ingenious mechanism based on two rings. One of the rings is mobile and is dedicated to the time, while the fixed ring is marked in days and months. By adjusting their position, the map can be set to the precise time and date required. A rotating semi-transparent sleeve reveals the visible part of the sky, indicates the horizon line, the compass points and the zenith.



CAEOGRAPH ZENITH
SOLID ROSE GOLD

FOUTAIN PEN / Unique piece per latitude: 20: 1633.681 / 45: 1633.481 / 30: 1633.581

M nib: rose gold 18 carats (other nib widths available on request)
24 diamonds – 22 diamonds set on the body, 1 diamond on the clip and 1 diamond on the piston pump
Refills: Ink and cartridges Chromatics Collection (p. 140 - 143)



CAEOGRAPH SIRIUS
GOLD-PLATED FINISH

FOUTAIN PEN / Latitude 20: 1632.681 / 45: 1632.481 / 30: 1632.581

M nib: gold 18 carats (other nib widths available on request)
1 diamond on the Sirius star
Refills: Ink and cartridges Chromatics Collection (p. 140 - 143)



CAEOGRAPH ALPHA
PLATINIUM FINISH

FOUTAIN PEN / Latitude 20: 1631.681 / 45: 1631.481 / 30: 1631.581

M nib: gold 18 carats (other nib widths available on request)
Refills: Ink and cartridges Chromatics Collection (p. 140 - 143)



CAEOGRAPH ZENITH
SOLID ROSE GOLD

ROLLER PEN / Latitude 20: 1643.681 / 45: 1643.481 / 30: 1643.581

Refills: Roller cartridge, fine or medium, blue or black (p. 144)



CAEOGRAPH SIRIUS
GOLD-PLATED FINISH

ROLLER PEN / Latitude 20: 1642.681 / 45: 1642.481 / 30: 1642.581

Refills: Roller cartridge, fine or medium, blue or black (p. 144)



CAEOGRAPH ALPHA
PLATINIUM FINISH

ROLLER PEN / Latitude 20: 1641.681 / 45: 1641.481 / 30: 1641.581

Refills: Roller cartridge, fine or medium, blue or black (p. 144)





The Caelograph case welcomes the new invention.
 Made of wood, gloss grey lacquered and screen printed. 3 removable wedges allowing each of these elements constituting the gift set to be positioned.

DELIVERED WITH THE CAEOLOGRAPH LIMITED EDITIONS:

- owner's guide book and guarantee
- two small ink cartridges or roller pen cartridge (F black)
- a Caelograph leather pouch and a Caelograph brochure

Dimensions: 263 x 193 x 100 mm.



THE INKWELL
 CAEOLOGRAPH

The Caelograph is accompanied by a personalised ink bottle, with a stopper produced in the same finish as the instrument. Depending on the model: palladium, golden 2n or golden 5n finish. It matches the finishing available on the writing instrument. The ink is "Blue Night" colour.

THE COMPASS ROSE
 CAEOLOGRAPH

For at least 2000 years, the compass has been used to indicate the magnetic north. By orienting the pen accurately, it makes the Caelograph easy to use. This indispensable instrument of navigation accompanies the Caelograph in reading the sky.
 Depending on the model: palladium, golden 2n or golden 5n finish.
 It matches the finishing available on the writing instrument.



THE BROCHURE
 CAEOLOGRAPH

26 cm x 24 cm
 22 interior pages
 Brochure available in 5 languages
 References:
 FR: 100013.519 / DE: 100013.521
 EN: 100013.520 / CN: 100013.524
 ES: 100013.522





SPECIAL
LIMITED EDITIONS



JUSTICE LEAGUE

Caran d'Ache presents its new JUSTICE LEAGUE TRINITY special edition in collaboration with Warner Bros. Caran d'Ache has joined forces with the superheroes of the Justice League to create a range of legendary writing instruments. To celebrate these iconic superheroes, the craftsmen of the Geneva-based company have pooled their know-how to face a number of extraordinary technical challenges. Style, audacity, power and timelessness... the Justice League special edition from Caran d'Ache reveals the super powers hidden deep inside each and every one of us.

A special edition made to measure

With its Justice League Trinity special edition, Caran d'Ache brings together three legendary superheroes of the Justice League, designing made-to-measure writing instruments in their honour. With their legendary super powers and iconic costumes, Superman, Batman and Wonder Woman express their unique characters in a range of pens created by the Geneva-based company.



Each detail of the Batman special edition is inspired by his costume. Thanks to the combination of different translucent and gloss lacquer finishes and the combination of different engravings, each part of the superhero's costume is highlighted. The attributes and fountain pen nib boast a black ceramic coating, PVD application. (PVD: physical vapour deposition) Cutting-edge technique for depositing the ceramic which optimises the adherence of the material. The ceramic is non-corrodible and extremely resistant to friction. The chevron pattern decorates the body and cap. The whole is finely cutter-engraved then coated with translucent gloss black lacquer. The ends of the cap and body are smooth and coated in gloss black lacquer. The cap button carries the new Caran d'Ache identification (grey-black lacquered hexagon). The 18-carat gold fountain pen nib is treated by PVD to ensure remarkable fluidity and writing comfort thanks to the properties of gold and the PVD. The pen ring is laser-engraved with Swiss Made & Caran d'Ache along with the DCTM trademark – and the note S17 to guarantee the authenticity and exclusivity of the edition.



JUSTICE LEAGUE TRINITY - BATMAN
BLACK PVD FINISH

FOUNTAIN PEN / M nib: 1939.481 (other nib widths available on request)

18-carat-gold nib with black ceramic coating by PVD
Refills: Ink and cartridges Chromatics Collection (p.140 - 143)



JUSTICE LEAGUE TRINITY - BATMAN
BLACK PVD FINISH

ROLLER PEN / 1939.461

Refills: Roller cartridge, fine or medium, blue or black (p. 144)



THE CASE
JUSTICE LEAGUE TRINITY BATMAN

195 x 102 x 68 mm
Made using fully-sheathed, screen-printed wood
The inner wedge is reversible and can house 1 or 2 pens
Delivered with the Justice League Trinity– Batman special edition:
- owner's guide book and guarantee
- two small ink cartridges or roller pen cartridge (F black)
The black case lining is decorated with the symbol of the superhero.





Each detail of the Wonder Woman special edition is inspired by her costume. The pattern of the bracelets is cutter-engraved on the first part of the cap. The raw (unpolished), silvery metallic finishes recall the costume. The second part of the cap is cutter-engraved and coated with translucent, burgundy-coloured lacquer to incorporate the metallic reflections of Wonder Woman's bustier. On the body of the writing instrument, the pattern of her boots is cutter-engraved in a highly graphic design. There are also raw (unpolished) metallic finishes recalling the look of the boots. The cap button carries the new Caran d'Ache identification – the red-burgundy lacquered hexagon. The fountain pen nib is 18-carat gold with 18-carat pink gold-plating for unique writing comfort. The pink-gold-engraved pen ring is laser-engraved with Swiss Made & Caran d'Ache along with the DCTM trademark – and the note S17 to guarantee the authenticity and exclusivity of the edition.



**JUSTICE LEAGUE TRINITY
WONDER WOMAN**
SILVERY PINK-GOLD-PLATED FINISH

FOUNTAIN PEN / M nib: 1941.481 (other nib widths available on request)
nib: 18 carat pink gold-plating
Refills: Ink and cartridges Chromatics Collection (p.140 - 143)



**JUSTICE LEAGUE TRINITY
WONDER WOMAN**
SILVERY PINK-GOLD-PLATED FINISH

ROLLER PEN / 1941.461
Refills: Roller cartridge, fine or medium, blue or black (p. 144)

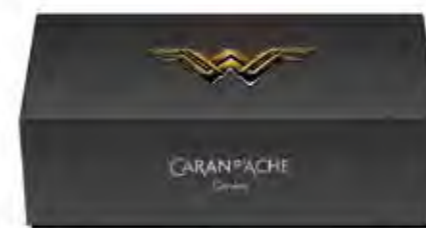

THE CASE
JUSTICE LEAGUE TRINITY
WONDER WOMAN

195 x 102 x 68 mm
Made using fully-sheathed, screen-printed wood
The inner wedge is reversible and can house 1 or 2 pens
Delivered with the Justice League Trinity– Wonder Woman special edition:
- owner's guide book and guarantee
- two small ink cartridges or roller pen cartridge (F black)
The black case lining is decorated with the symbol of the superhero.



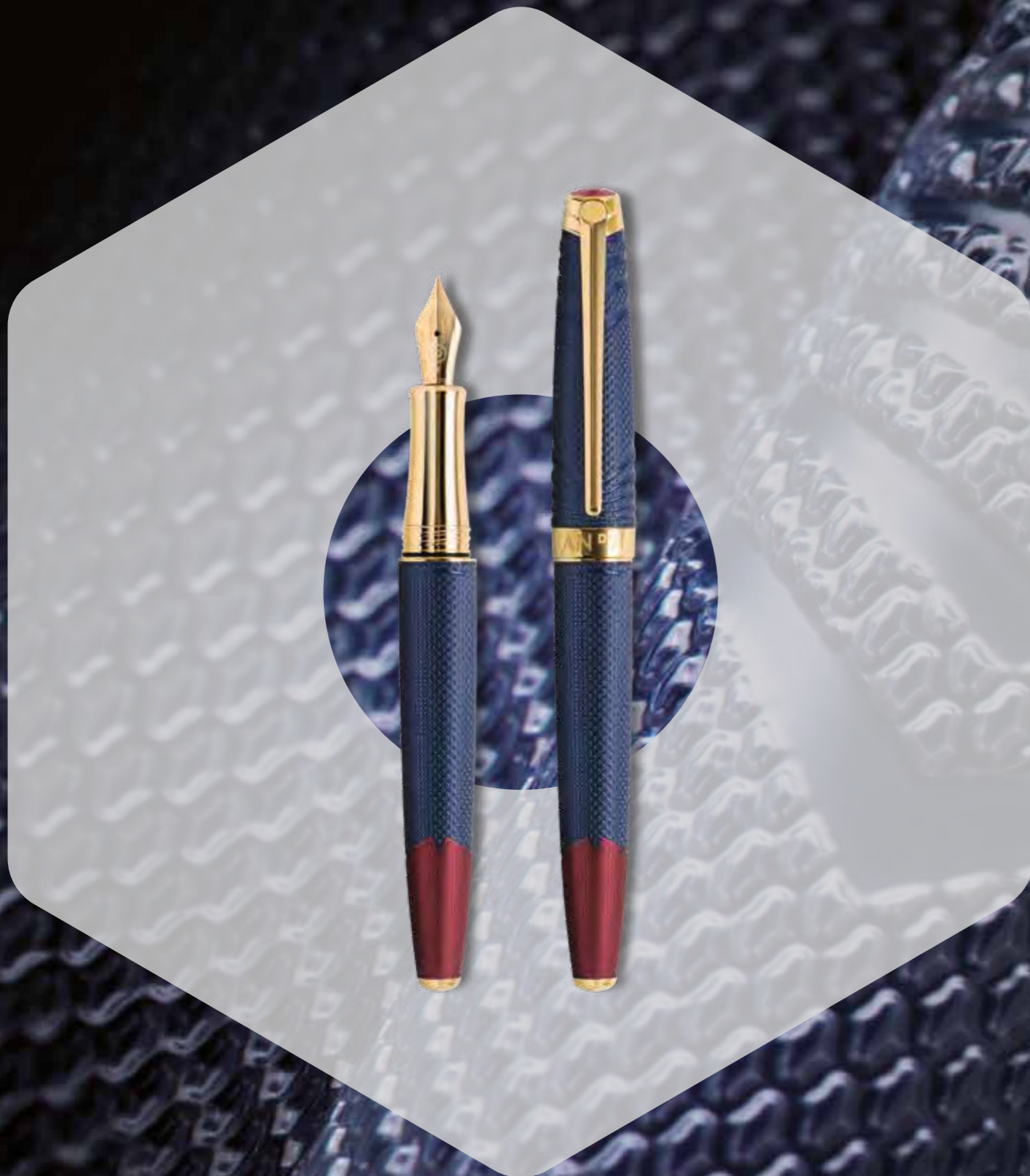

Each detail of the Superman special edition is inspired by his costume. Thanks to the combination of different dense and gloss lacquer finishes, the combination of different engravings and the combination of different colours of lacquer, each part of the superhero's costumer is highlighted. The attributes and fountain pen nib are coated in brightly-polished 18-carat yellow gold. The metallic appearance and scaly texture of the costume are reinterpreted by different cutter-engraved elements. The body and cap are engraved and coated in dense gloss blue lacquer. The cap recalls the hero's torso and the body of the pen his legs. The extremity of the pen body is coated in dark red lacquer and boasts a new engraving inspired by Superman's boots. The cap button carries the new Caran d'Ache identification – the dark red lacquered hexagon. The fountain pen nib is 18-carat gold with 18-carat yellow gold-plating for unique writing comfort. The gold-plated pen ring is laser-engraved with Swiss Made & Caran d'Ache along with the DCTM trademark – and the note S17 to guarantee the authenticity and exclusivity of the edition.



JUSTICE LEAGUE TRINITY SUPERMAN
GOLD-PLATING FINISH

FOUNTAIN PEN / M nib: 1938.481 (other nib widths available on request)

nib: 18 carat gold-plating
Refills: Ink and cartridges Chromatics Collection (p.140 - 143)



JUSTICE LEAGUE TRINITY SUPERMAN
GOLD-PLATING FINISH

ROLLER PEN / 1938.461

Refills: Roller cartridge, fine or medium, blue or black (p. 144)



THE CASE
JUSTICE LEAGUE TRINITY
SUPERMAN

195 x 102 x 68 mm
Made using fully-sheathed, screen-printed wood
The inner wedge is reversible and can house 1 or 2 pens
Delivered with the Justice League Trinity – Superman special edition:
- owner's guide book and guarantee
- two small ink cartridges or roller pen cartridge (F black)
The black case lining is decorated with the symbol of the superhero.



A very exclusive edition of the JUSTICE LEAGUE TRINITY is also available.

An exceptional trilogy box set bringing all 3 heroes together. The JUSTICE LEAGUE TRINITY special Trilogy edition is limited to 60 items. The generic numbering is engraved on a metal plate on the box: Limited editions 1 in 60 pieces. 60 «Trilogy» gift sets are available with the fountain pen version and 60 «Trilogy» gift sets are available with the roller pen. The number 60 refers to 1960, the year in which the first issue of Justice League comics appeared.

Fountain pen trilogy: 1960.481 / **Roller pen trilogy:** 1960.461.



The JUSTICE LEAGUE case holds the 3 heroes of the special edition.

Made using fully-sheathed and screen-printed wood.

The black case lining is decorated with the identity of the 3 superheroes.

The inner wedge can be removed and houses 3 pens.

THE JUSTICE LEAGUE TRINITY SPECIAL EDITION IN ITS EXCEPTIONAL «TRILOGY» BOX SET:

- with its user guide / guarantee

- six small blue ink cartridges or three black F roller cartridges and the edition brochure

The case lining is black

Dimensions: 263 x 193 x 90 mm



**ADVERTISING AT
THE POINT OF SALE**
JUSTICE LEAGUE TRINITY

An exclusive window presentation is available.

THE BROCHURE
JUSTICE LEAGUE TRINITY

26 x 19 cm
Trilingual brochure: FR / DE / EN
12 interior pages
Reference: 100015.697





VARIUS PETER MARINO

Caran d'Ache is unveiling two new exceptional creations, Varius Peter Marino and Varius Peter Marino - Special Edition, dreamed up by the famous American architect, talented designer and lover of fine materials. The Varius writing instruments by Caran d'Ache are an intrinsic part of the designer's life. He has always used them to draw his magnificent buildings.

Caran d'Ache's iconic collection

Varius is the result of the passionate work with materials. The artisans exalts the noblest materials such as Chinese lacquer, carbon fibre, chain mail or ebony wood on the body of these fine creations. Precision, expertise and elegance are the hallmarks of this collection with superb writing comfort.

The two Varius Peter Marino versions are covered with leather, which provides unrivalled comfort. The architect's rock 'n' roll world fuses with the spirit of Varius writing instruments to ink two creations, which are simultaneously modern, surprising and fashionable. The essential values of the Varius collection are nonetheless safeguarded. Original materials do full justice to a custom-made approach, and ancestral skills are applied to creating high-end models.



The Varius Peter Marino - Special Edition, designed by the architect, reflects his unique personality. The daring attributes of these instruments, symbolising strength according to Peter Marino, are interpreted by Caran d'Ache with good taste and expertise. A hand-made lacing goes through rhodium and silver-coated eyelets. The cap is topped by a silver-plated, rhodium-coated skull with black onyx eyes, reminiscent of the many rings adorning Peter Marino's fingers.

The bodies of the writing instruments are sheathed in French calfskin. Boasting a highly natural appearance, this elegant leather is used by the leading luxury leather goods boutiques. The patina of the leather will appear with time and use, giving it an authentic look.

A generic numbering system, 1/150 (one out of 150), evokes the address of the architect's Manhattan studio: 150 East 58 Street.

This is engraved on the cap at a scale of 1/150 along with Peter Marino's handwritten signature.



**VARIUS PETER MARINO
SPECIAL EDITION**
SILVER-PLATED,
RHODIUM-COATED FINISH

FOUNTAIN PEN / M nib: 1653.491 (other nib widths available on request)

nib: 18 carat gold, rhodium-coated
Refills: Ink and cartridges Chromatics Collection (p.140 - 143)



**VARIUS PETER MARINO
SPECIAL EDITION**
SILVER-PLATED,
RHODIUM-COATED FINISH

ROLLER PEN / 1653.471

Refills: Roller cartridge, fine or medium, blue or black (p. 144)



THE CASE
VARIUS PETER MARINO
SPECIAL EDITION

195 x 102 x 68 mm
Made using wood entirely sheathed in imitation leather and fine black stitching. The whole is screen-printed.
The inner wedge is specifically designed to hold the instrument.
The Peter Marino Varius special edition is delivered:
- with its user guide / guarantee
- two small blue ink cartridges or one black F roller cartridge
- the edition brochure



VARIUS PETER MARINO
SILVER-PLATED,
RHODIUM-COATED FINISH

FOUNTAIN PEN / M nib: 1652.491 (other nib widths available on request)

nib: 18 carat gold, rhodium-coated
Refills: Ink and cartridges Chromatics Collection (p.140 - 143)



VARIUS PETER MARINO
SILVER-PLATED,
RHODIUM-COATED FINISH

ROLLER PEN / 1652.471

Refills: Roller cartridge, fine or medium, blue or black (p. 144)



VARIUS PETER MARINO
SILVER-PLATED,
RHODIUM-COATED FINISH

BALLPOINT PEN / 1652.481

Refills: Goliath cartridge, large, medium or fine (p. 144)



THE CASE
VARIUS PETER MARINO

195 x 102 x 68 mm
Made using wood entirely sheathed in imitation leather and fine black stitching. The whole is screen-printed.
The inner wedge is reversible and can house 1 or 2 pens
The Peter Marino Varius edition is delivered:
- with its user guide /guarantee
- two small blue ink cartridges or one black F roller cartridge
- the edition brochure

ADVERTISING AT THE POINT OF SALE
VARIUS PETER MARINO

An exclusive window presentation is available



THE BROCHURE
VARIUS PETER MARINO

9.5 x 19 cm
16 interior pages
Bilingual brochure: French / English
Reference: 100015.833

The specially created Varius Peter Marino limited editions is entirely in tune with the spirit of this man with a resolutely modern personality. The body of these Haute Ecriture instruments is clothed in leather, carefully crafted to ensure unprecedented comfort. Like a nod to the world of fashion dear to Peter Marino's heart, a slim grey seam adorns the entire length of the instrument. A unique engraved limited-edition number pays tribute to the date he set up his first New York studio: 1/1978 (one out of 1,978). The generic numbering is engraved on the cap at a scale of 1/1978 along with Peter Marino's handwritten signature.





HOMMAGE

LIMITED EDITIONS





OBERALP

Following the limited editions Poya and Rindya dedicated to the Swiss customs and Alpine traditions, the new creation Oberalp salutes the refined expertise of the Caran d'Ache artisans in terms of figurative engraving. The Maison Caran d'Ache has developed the Oberalp limited editions in tribute to the Alpine spirit that is inextricably bound up with the intrinsic Swiss identity. The fascination of the mountains and its lively folklore, expressed through song, paintings, paper-cutting or the engravings on chalet façades, represent a living heritage that perpetuates the enduring Alpine spirit.

The Oberalp Pass

An iconic site within the Swiss Alpine heritage, the Oberalp Pass is located at an altitude of 2,044 metres at the very heart of the Swiss Alps. It links the Rhone and Rhine valleys along the watershed between North and South. From the start of the 19th century, Swiss alpine passes became the independent and neutral guardians of the major, transalpine communication routes. They continue to provide a crossing through the Alps to this day.

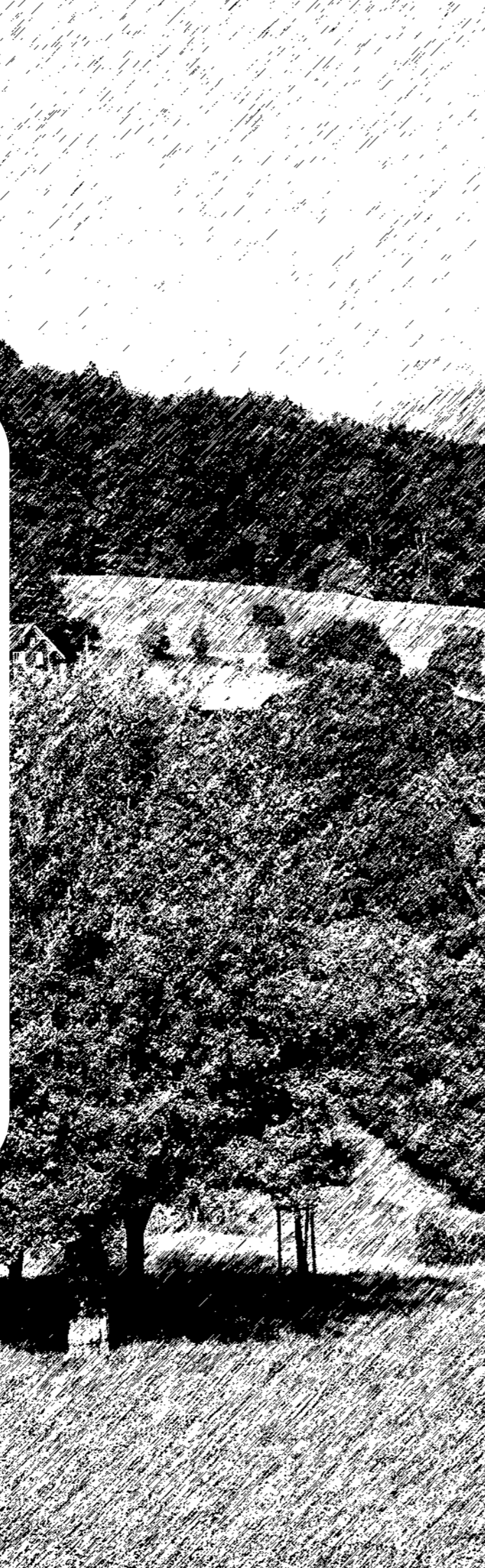

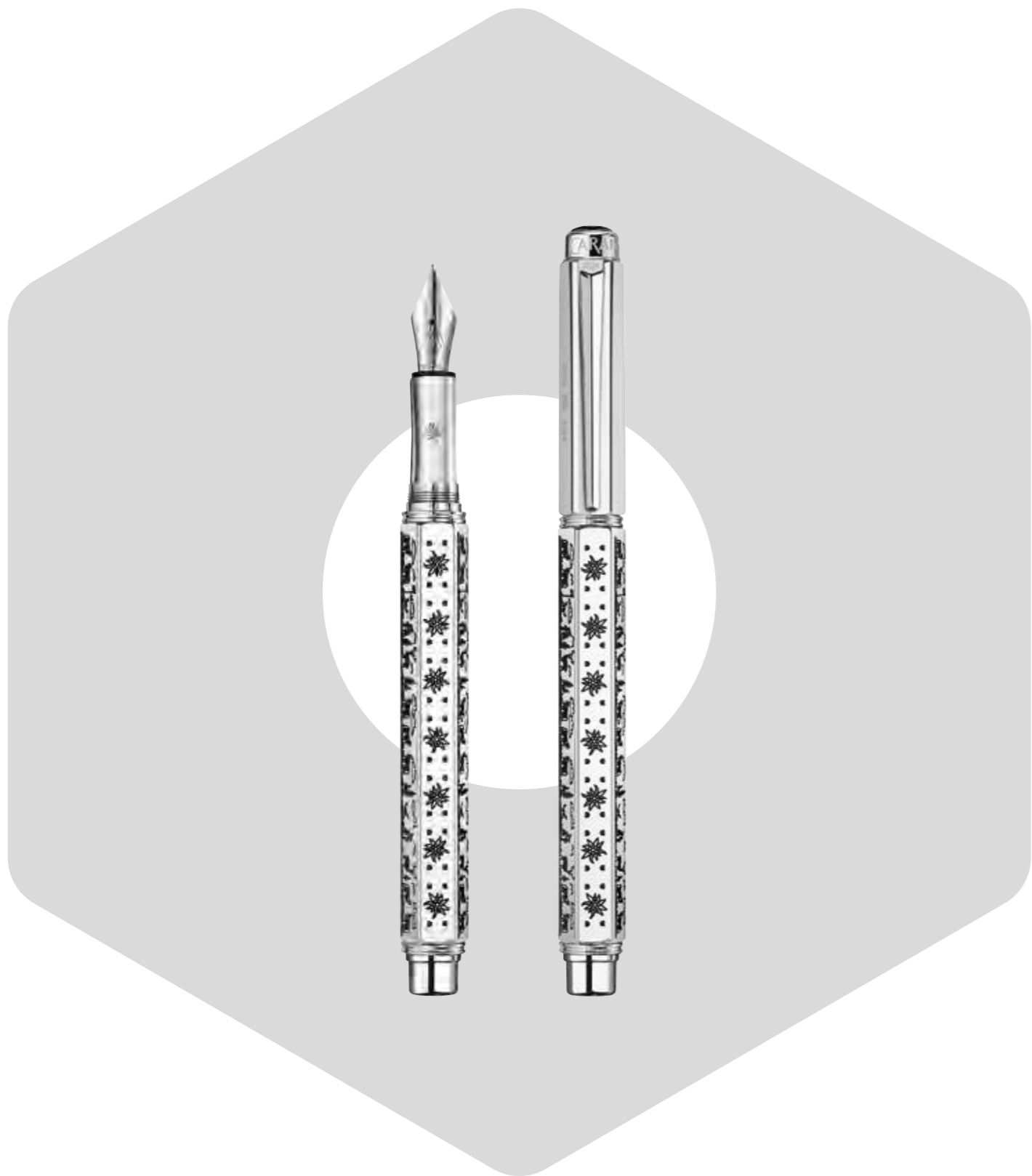

The Oberalp Limited editions is dedicated to the mountain and Alpine spirit. A narrative frieze motif evokes the symbols of Alpine life and the idyllic scenery of the Swiss mountains. A second frieze, engraved on the other three sides of the pen, portrays the beauty of edelweiss flowers. Crafting these miniature frieze motifs reflects the finesse of the traditional Alpine art of paper- or wood-cutting. Each item is decorated with black lacquer applied entirely by hand. The body of the fountain pens and roller pens features the finely engraved outlines of three edelweiss blossoms. Paying symbolic homage to the highest point of the Oberalp Pass, Oberalp writing instruments are issued in a numbered series of 2,044.



OBERALP
SILVER-PLATED,
RHODIUM-COATED FINISH

FOUNTAIN PEN / M nib: 1651.481 (other nib widths available on request)

nib: 18 carat gold, rhodium-coated
Refills: Ink and cartridges Chromatics Collection (p.140 - 143)



OBERALP
SILVER-PLATED,
RHODIUM-COATED FINISH

ROLLER PEN / 1661.481

Refills: Roller cartridge, fine or medium, blue or black (p. 144)



OBERALP
SILVER-PLATED,
RHODIUM-COATED FINISH

BALLPOINT PEN / 1671.481

Refills: Goliath cartridge, large, medium or fine (p. 144)



THE CASE
OBERALP

225 x 110 x 110 mm
Made from solid beech sourced in Switzerland
Its shape reflects the design of a high alpine chalet and the edition's frieze is engraved onto the case.
The inner wedge is reversible and can house 1 or 2 pens
The Oberalp case holds the limited editions:
- its shape reflects the design of a high alpine chalet and the edition's frieze is engraved onto the case.
- the inner wedge is reversible and can house 1 or 2 pens

THE BROCHURE
OBERALP

24.5 x 10.7 cm
12 interior pages
Brochure available in 3 languages
References:
FR: 100014.949
EN: 100014.950
DE: 100014.951





SPIRIT OF SWITZERLAND

To mark its 100th anniversary, Caran d'Ache pays tribute to its country with a limited editions of writing instruments, Spirit of Switzerland. This symbolic creation presents 14 elements of Swiss cultural identity.

Located at the heart of Europe and home to the snow-capped peaks of the Alps and the Jura, Switzerland enjoys international renown through its exceptional know-how, its iconic products, its idyllic countryside and its humanistic spirit. Swiss culture is characterised by its rich heritage, the incredible beauty of its natural landscapes and the unrelenting quest for perfection and quality in all areas of life.

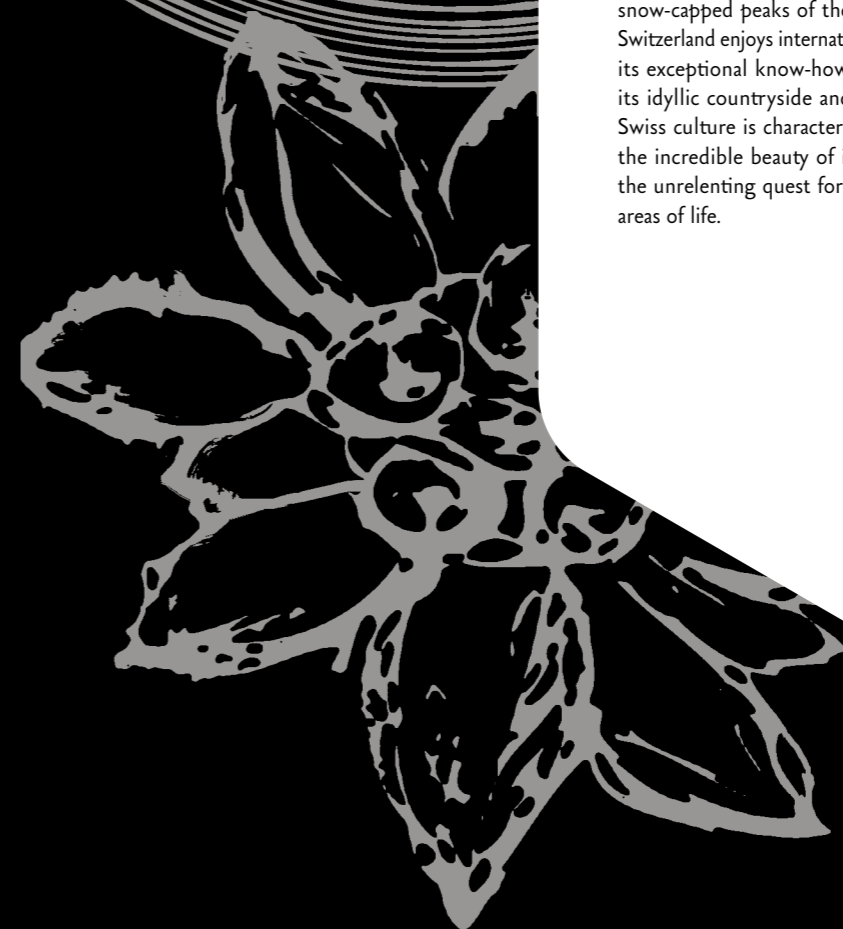



SPIRIT OF SWITZERLAND
SOLID SILVER FINISH

FOUNTAIN PEN / M nib: 5090.051 (other nib widths available on request)

nib: 18 carat gold, rhodium-coated
Refills: Ink and cartridges Chromatics Collection (p. 140 - 143)



SPIRIT OF SWITZERLAND
SOLID SILVER FINISH

ROLLER PEN / 5070.051

Refills: Roller cartridge, fine or medium, blue or black (p. 144)

THE CASE
SPIRIT OF SWITZERLAND

223 x 163 x 90 mm
Made from screen-printed brilliant grey-lacquered wood
The inner wedge is reversible and can house 1 or 2 pens
The Spirit of Switzerland limited editions is delivered:
- with its user guide /guarantee
- two small blue ink cartridges or one black F roller cartridge or a black M Goliath cartridge



THE BROCHURE
SPIRIT OF SWITZERLAND

14 x 20 cm
8 interior pages
Brochure available in 3 languages
References:
Fr: 100014.979
En: 100014.980
De: 100014.981

The Limited editions dedicated to Switzerland featuring 14 figurative representations, emblematic of Swiss cultural identity. The figures appearing in relief, sculpted in solid silver and adorning the body of the pens, represent the emblematic sectors that make Switzerland and its cultural heritage shine across the world. The delicately carved figurative structure appears superimposed on the matt black lacquer body of the fountain and roller pens. Friezes engraved with Swiss crosses form delicate borders at the far ends of each part of the writing instrument. The Spirit of Switzerland limited editions consists of 100 numbered fountain and roller pens, in symbolic tribute to the 100th anniversary of the Maison Caran d'Ache.





CHINESE ZODIAC

Caran d'Ache pays homage to the fine arts in its "Chinese calendar" collection, designed to bring the legend of the symbols of the Chinese zodiac to life. According to legend, the Jade Emperor invited all the animals to a mysterious gathering one New Year's Eve. He wanted to organise a race between the different species to establish a hierarchy among the animals. Only twelve animals accepted the invitation. The Emperor then gave each animal a unique gift: henceforth, a year would be dedicated to them and would bear their name. This is how the order of the animal signs of the Chinese zodiac was established.

- 1. The Rat - 鼠 5. The Dragon - 龍 9. The Monkey - 猴
- 2. The Ox - 牛 6. The Snake - 蛇 10. The Rooster - 鷄
- 3. The Tiger - 虎 7. The Horse - 馬 11. The Dog - 狗
- 4. The Hare - 兔 8. The Goat - 羊 12. The Pig - 猪



In keeping with the aesthetics of previous limited editions dedicated to the symbols of the Chinese zodiac, the "Year of the Dog" limited editions, carries on the tradition of this collection of exceptional writing instruments to celebrate the advent of the Chinese Year of the Dog in 2018. The slim silhouette of the dog appears against a background of black gloss Chinese lacquer, patiently applied layer by layer according to the ancestral tradition. The finely engraved drawing presents the animal in an alert posture, wrapped around the body of the writing instrument. Represented in grey Chinese lacquer, the lines and figurative contours highlight the liveliness and subtle elegance of the dog. The typically Asian character of the design further underlines its rippling coat and the arching of its slender body so full of vitality.



THE YEAR OF THE DOG

In the Chinese zodiac, the dog symbolises loyalty, integrity and devotion to just causes. Its profound intelligence, sensitive soul and alert mind often make it the defender of universal values. A loyal friend and reliable travelling companion, this pathfinder for peace brings balance and harmony to the world. Favourable to stability and positive change, the Chinese Year of the Dog promises the union of the very best energies.

CHINESE LACQUER

Known since the 14th century BCE, the art of Chinese lacquer was developed during the reign of the Shang dynasty. The natural material comes from the sap of the Rhus Vernicifera tree, which is native to tropical Asia. Produced entirely by hand, the meticulous application of successive thin layers of lacquer requires unflinching patience. The hand polishing reveals its incomparable hues.

中國漆



YEAR OF THE DOG
GOLD-PLATED FINISH

FOUNTAIN PEN / M nib: 5092.054 (other nib widths available on request)

nib: 18 carat gold
Refills: Ink and cartridges Chromatics Collection (p.140 - 143)



YEAR OF THE DOG
GOLD-PLATED FINISH

ROLLER PEN / 5072.054

Refills: Roller cartridge, fine or medium, blue or black (p. 144)

THE CASE
YEAR OF THE DOG

195 x 102 x 68 mm
Made from screen-printed, brilliant black-lacquered wood
The inner wedge is reversible and can house 1 or 2 pens
The Year of the Dog limited editions is delivered:
- with its user guide /guarantee
- two small blue ink cartridges or one black F roller cartridge
- the certificate of authenticity of the Chinese lacquer
- the edition brochure



THE BROCHURE
YEAR OF THE DOG

14 x 20 cm
8 interior pages
Bilingual brochure: Chinese / English
Reference: 100016.173

CASE INCLUDING
12 GREETING CARDS

14.8 x 21 cm
Tribute to the 12 signs of the Chinese zodiac
Designed by the calligrapher Lam Chi Van
Reference: 100015.280





YEAR OF THE DRAGON
GOLD-PLATING FINISH

FOUNTAIN PEN / M nib: 5092.036 (other nib widths available on request)
nib: 18 carat gold
Refills: Ink and cartridges Chromatics Collection (p.140 - 143)



YEAR OF THE SNAKE
GOLD-PLATING FINISH

FOUNTAIN PEN / M nib: 5092.037 (other nib widths available on request)
nib: 18 carat gold
Refills: Ink and cartridges Chromatics Collection (p.140 - 143)



YEAR OF THE HORSE
GOLD-PLATING FINISH

FOUNTAIN PEN / M nib: 5092.050 (other nib widths available on request)
nib: 18 carat gold
Refills: Ink and cartridges Chromatics Collection (p.140 - 143)



YEAR OF THE DRAGON
GOLD-PLATED FINISH

ROLLER PEN / 5072.036
Refills: Roller cartridge, fine or medium, blue or black (p. 144)



YEAR OF THE SNAKE
GOLD-PLATED FINISH

ROLLER PEN / 5072.037
Refills: Roller cartridge, fine or medium, blue or black (p. 144)



YEAR OF THE HORSE
GOLD-PLATED FINISH

ROLLER PEN / 5072.050
Refills: Roller cartridge, fine or medium, blue or black (p. 144)



THE BROCHURE
YEAR OF THE DRAGON

14 x 20 cm
8 interior pages
Bilingual brochure: Chinese / English
Reference: 100013.035

THE BROCHURE
YEAR OF THE SNAKE

14 x 20 cm
8 interior pages
Bilingual brochure: Chinese / English
Reference: 100013.941



THE BROCHURE
YEAR OF THE HORSE

14 x 20 cm
8 interior pages
Bilingual brochure: Chinese / English
Reference: 100013.370





YEAR OF THE GOAT
GOLD-PLATING FINISH

FOUTAIN PEN / M nib: 5092.051 (other nib widths available on request)
nib: 18 carat gold
Refills: Ink and cartridges Chromatics Collection (p.140 - 143)



YEAR OF THE MONKEY
GOLD-PLATING FINISH

FOUTAIN PEN / M nib: 5092.052 (other nib widths available on request)
nib: 18 carat gold
Refills: Ink and cartridges Chromatics Collection (p.140 - 143)

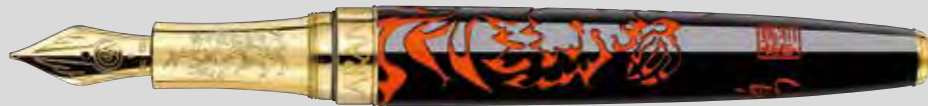

YEAR OF THE ROOSTER
GOLD-PLATING FINISH

FOUTAIN PEN / M nib: 5092.053 (other nib widths available on request)
nib: 18 carat gold
Refills: Ink and cartridges Chromatics Collection (p.140 - 143)



YEAR OF THE GOAT
GOLD-PLATED FINISH

ROLLER PEN / 5072.051
Refills: Roller cartridge, fine or medium, blue or black (p. 144)



YEAR OF THE MONKEY
GOLD-PLATED FINISH

ROLLER PEN / 5072.052
Refills: Roller cartridge, fine or medium, blue or black (p. 144)



YEAR OF THE ROOSTER
GOLD-PLATED FINISH

ROLLER PEN / 5072.053
Refills: Roller cartridge, fine or medium, blue or black (p. 144)



THE BROCHURE
YEAR OF THE GOAT

14 x 20 cm
8 interior pages
Bilingual brochure: Chinese / English
Reference: 100014.785

THE BROCHURE
YEAR OF THE MONKEY

14 x 20 cm
8 interior pages
Bilingual brochure: Chinese / English
Reference: 100015.244

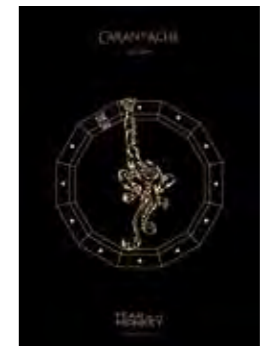

THE BROCHURE
YEAR OF THE ROOSTER

14 x 20 cm
8 interior pages
Bilingual brochure: Chinese / English
Reference: 100015.727

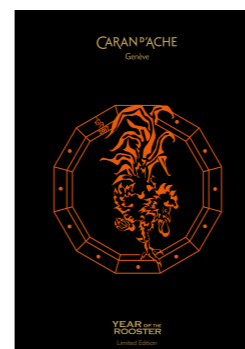



COLLECTIONS



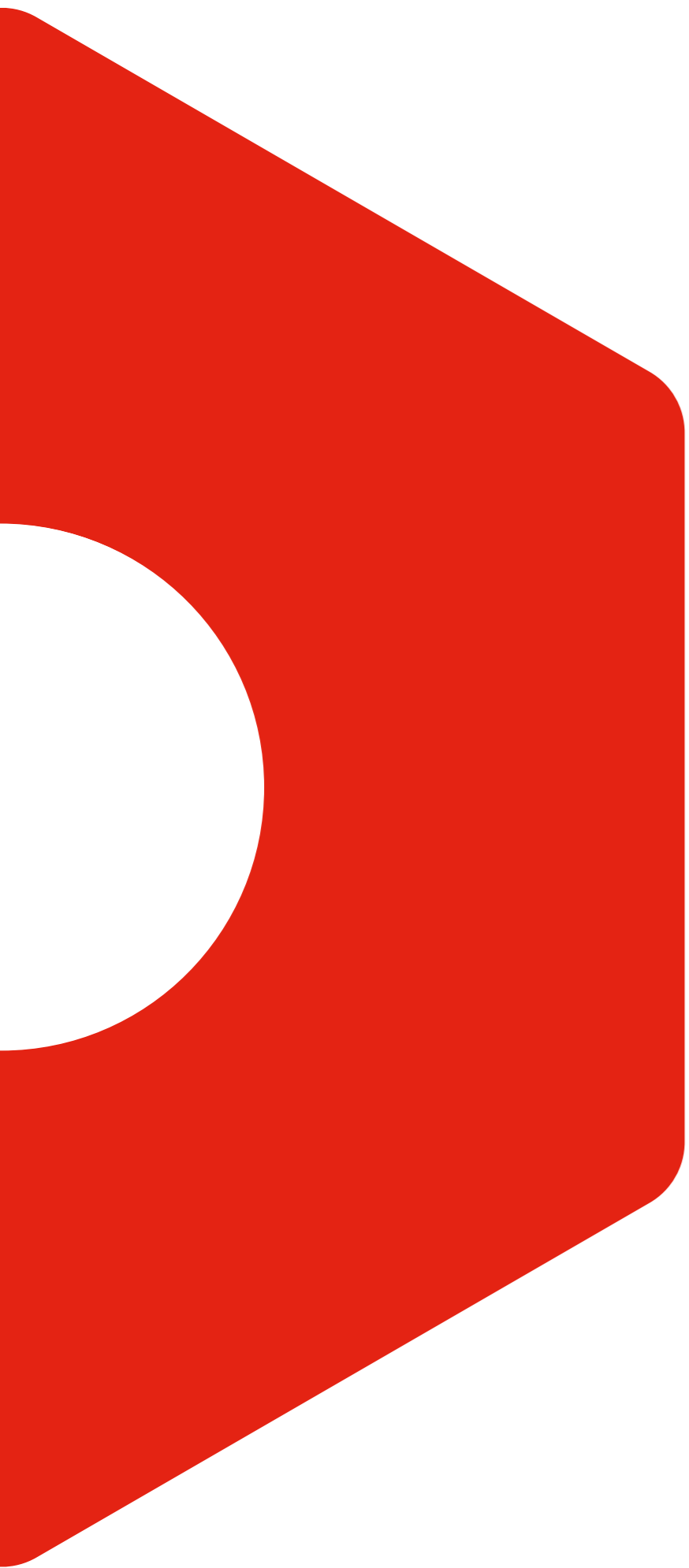

VARIUS

An accomplished form and hexagonal body with a unique feel... Caran d'Ache's iconic Varius collection is the result of our passionate work with materials. Chinese lacquer, carbon fibre, chain mail, ceramic and more recently genuine rubber and ebony wood echo the precious coating of this writing instrument. A rare conjunction of striking design and superb writing comfort, Varius is the only collection to offer fountain pen nibs in six widths, turning the art of handwriting into a daily pleasure.

- Four writing instruments:
 - Fountain pen, roller pen, ballpoint pen, mechanical pencil
 - Brass body finished in various materials
 - Flexible clip
 - Silver, rhodium, gold plated and rose gold plated attributes
 - 18 carat gold nib available in six distinct widths:
EF, F, M, B, OM, OB (BB nib available upon request)
- Can be customised by means of personalised engraving
- International lifetime guarantee
- Made in Switzerland



EBONY WOOD

Originating from the Asian and African rainforests, ebony is highly valued by artisans for its deep black colour and delicate feel. Caran d'Ache craftsmen magnify this noble wood with rose gold, revealing its subtle and precious grains.



THE CASE VARIUS

184 x 80 x 40 mm
Standard screen-printed case
Includes:
- the user guide / guarantee
- two small blue ink cartridges or one black F roller cartridge or a black M Goliath cartridge



VARIUS EBONY PINK-GOLD-PLATED FINISH

FOUNTAIN PEN / Bec M-4490.142

nib sizes: B -.152 / F -.132 / EF -.122 / OM -.112 / OB -.102
nib: 18 carat gold, rose-gold plated
Piston ink pump or ink cartridge
Cap: Screw
Refill: Ink and cartridges Chromatics Collection (p.140 -143)



VARIUS EBONY PINK-GOLD-PLATED FINISH

ROLLER PEN / 4470.142

Cartridge
Cap: Screw
Refills: Roller cartridge, fine or medium, blue or black (p. 144)



VARIUS EBONY PINK-GOLD-PLATED FINISH

BALLPOINT PEN / 4480.142

Cartridge
Mechanism: Push button
Refills: Goliath cartridge, large, medium or fine (p.144)



VARIUS EBONY PINK-GOLD-PLATED FINISH

MECHANICAL PENCIL / 4460.142

0.7mm lead
Mechanism: Push button
Refills: 0.7 mm graphite leads, HB or B and replacement erasers (p.145)



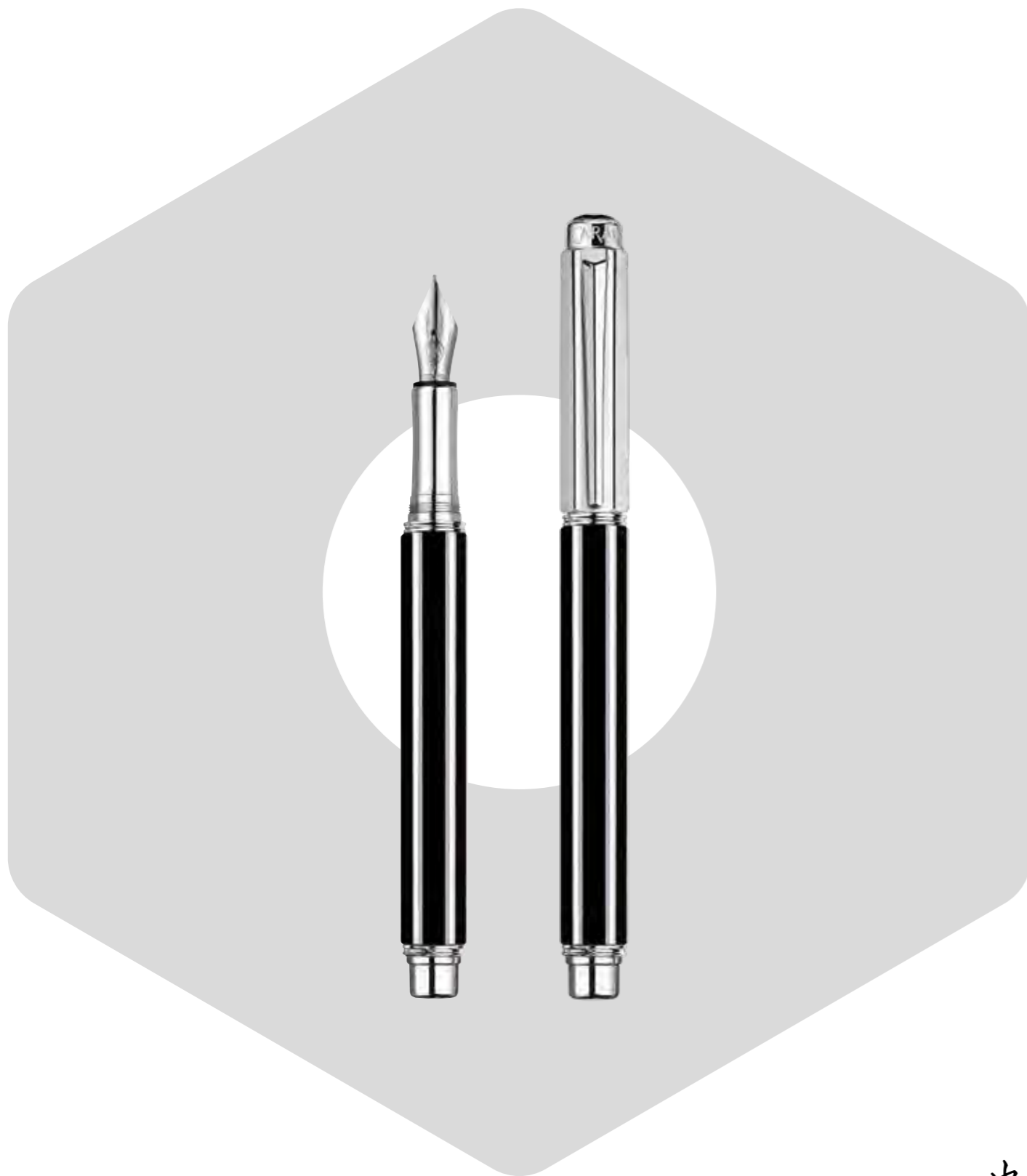

CHINESE LACQUER

Caran d'Ache is proud to be one of the very few Western manufacturers of writing instruments to use this wonderful material. Chinese lacquer gives a magnificent finish to lighters and writing instruments in the Varius collection as well as some limited editions. This natural product is derived from the sap of the "Rhus Verniciflua" tree. Caran d'Ache's craftsmen have been inspired by the highly complex art of preparing and applying it in the manner of the great Eastern masters.

中國漆



VARIUS CHINABLACK
SILVER-PLATED,
RHODIUM-COATED FINISH

FOUNTAIN PEN / M-4490.020

Nib sizes: B - .030 / F - .010 / EF - .990 / OM - .980 / OB - .970
 nib: 18 carat gold, rhodium-coated
 Piston ink pump or ink cartridge
 Cap: Screw
 Refill: Ink and cartridges Chromatics Collection (p.140 -143)



VARIUS CHINABLACK
SILVER-PLATED,
RHODIUM-COATED FINISH

ROLLER PEN / 4470.020

Cartridge
 Cap: Screw
 Refills: Roller cartridge, fine or medium, blue or black (p. 144)



VARIUS CHINABLACK
SILVER-PLATED,
RHODIUM-COATED FINISH

BALLPOINT PEN / 4480.020

Cartridge
 Mechanism: Push button
 Refills: Goliath cartridge, large, medium or fine (p.144)



VARIUS CHINABLACK
SILVER-PLATED,
RHODIUM-COATED FINISH

MECHANICAL PENCIL / 4460.020

0.7mm lead
 Mechanism: Push button
 Refills: 0.7 mm graphite leads, HB or B and replacement erasers (p.145)



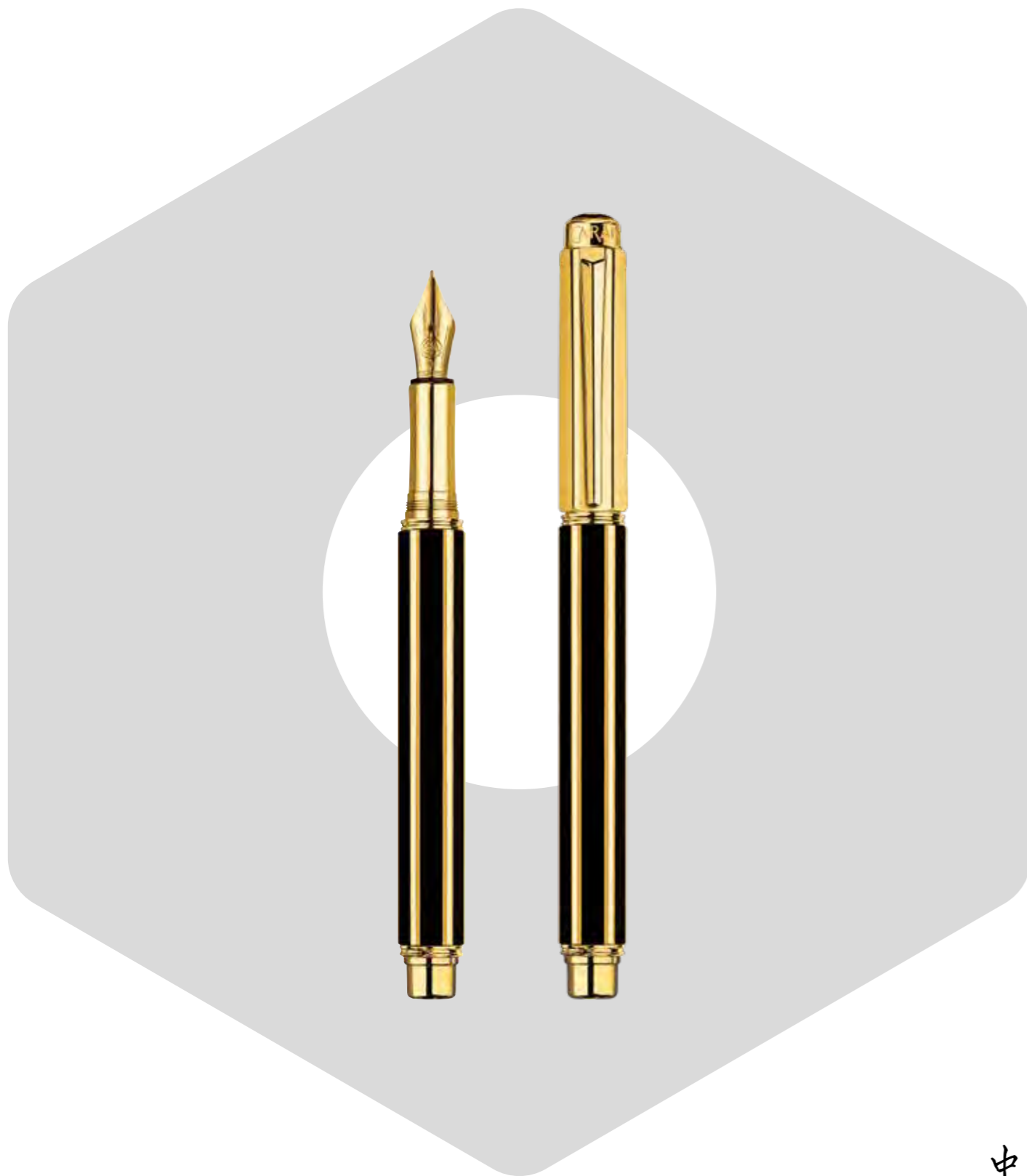

CHINESE LACQUER

Caran d'Ache is proud to be one of the very few Western manufacturers of writing instruments to use this wonderful material. Chinese lacquer gives a magnificent finish to lighters and writing instruments in the Varius collection as well as some limited editions. This natural product is derived from the sap of the "Rhus Verniciflua" tree. Caran d'Ache's craftsmen have been inspired by the highly complex art of preparing and applying it in the manner of the great Eastern masters.

中國漆



VARIUS CHINABLACK
GOLD-PLATED FINISH

FOUNTAIN PEN / M-4490.018

nib sizes: B - .028 / F - .008 / EF - .998 / OM - .988 / OB - .978
 nib: 18 carat gold, gold plated
 Piston ink pump or ink cartridge
 Cap: Screw
 Refill: Ink and cartridges Chromatics Collection (p.140 -143)



VARIUS CHINABLACK
GOLD-PLATED FINISH

ROLLER PEN / 4470.018

Cartridge
 Cap: Screw
 Refills: Roller cartridge, fine or medium, blue or black (p. 144)



VARIUS CHINABLACK
GOLD-PLATED FINISH

BALLPOINT PEN / 4480.018

Cartridge
 Mechanism: Push button
 Refills: Goliath cartridge, large, medium or fine (p.144)



VARIUS CHINABLACK
GOLD-PLATED FINISH

MECHANICAL PENCIL / 4460.018

0.7mm lead
 Mechanism: Push button
 Refills: 0.7 mm graphite leads, HB or B and replacement erasers (p.145)



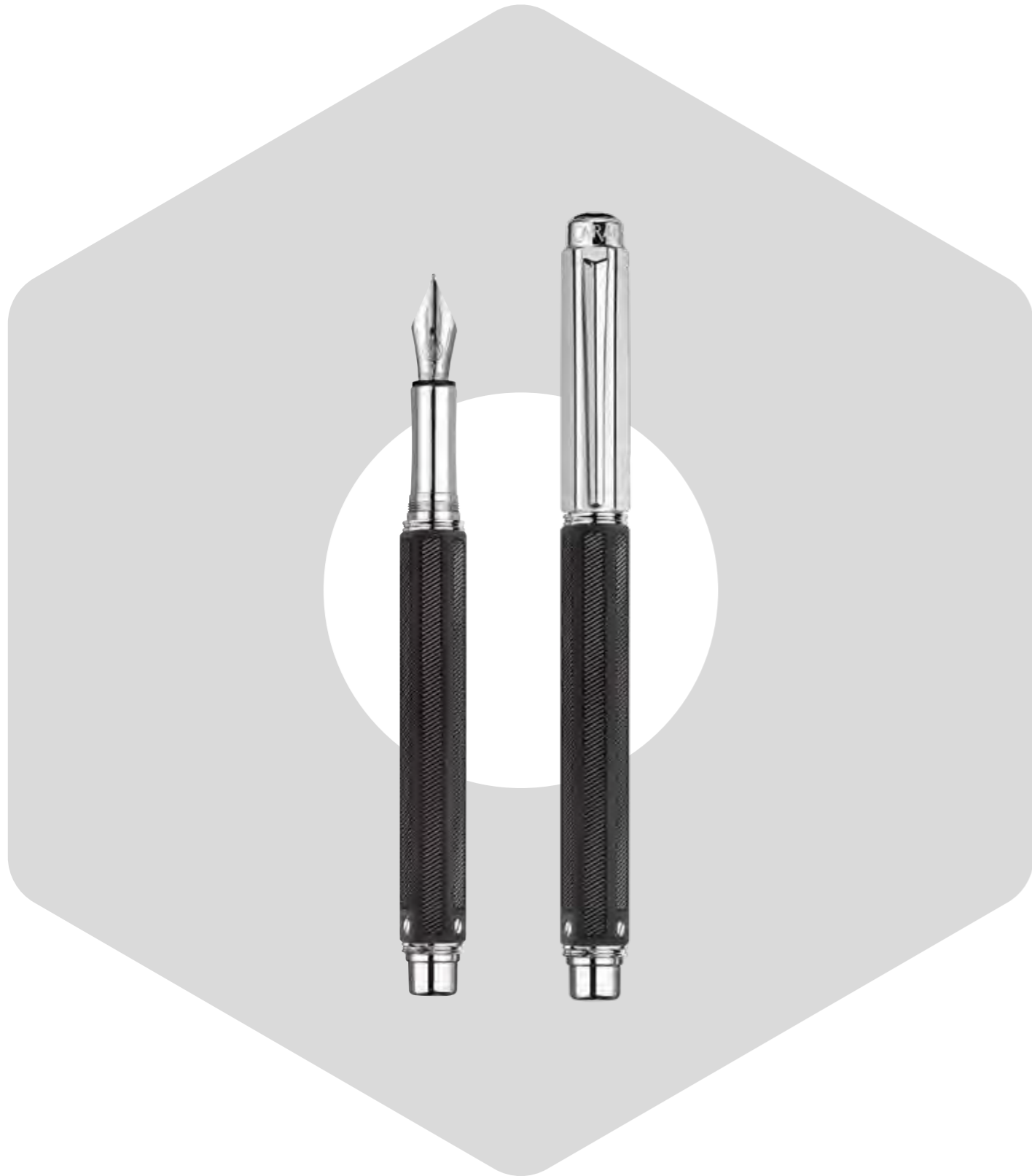

GENUINE RUBBER
 This material has a strong character and contemporary, urban elegance. Its inclusion in the Varius design promises an eminently masculine stroke. The brilliant rhodium contrasts with the soft matte rubber allowing the Rubracer to meet the demands and requirements of today's men. A screw inserted in the body of the pen, the newly articulated clip on the cap, and the broader nib confirm the Varius collection's energy and modernity.



VARIUS RUBRACER
 SILVER-PLATED,
 RHODIUM-COATED FINISH

FOUNTAIN PEN / M-4490.085
 nib sizes: B-.095 / F-.075 / EF.065 / OM.055 / OB.045 / BB.105
 nib: 18 carat gold, rhodium-coated
 Piston ink pump or ink cartridge
 Cap: Screw
 Refill: Ink and cartridges Chromatics Collection (p.140 -143)



VARIUS RUBRACER
 SILVER-PLATED,
 RHODIUM-COATED FINISH

ROLLER PEN / 4470.085
 Cartridge
 Cap: Screw
 Refills: Roller cartridge, fine or medium, blue or black (p. 144)



VARIUS RUBRACER
 SILVER-PLATED,
 RHODIUM-COATED FINISH

BALLPOINT PEN / 4480.085
 Cartridge
 Mechanism: Push button
 Refills: Goliath cartridge, large, medium or fine (p.144)



VARIUS RUBRACER
 SILVER-PLATED,
 RHODIUM-COATED FINISH

MECHANICAL PENCIL / 4460.085
 0.7mm lead
 Mechanism: Push button
 Refills: 0.7 mm graphite leads, HB or B and replacement erasers (p.145)

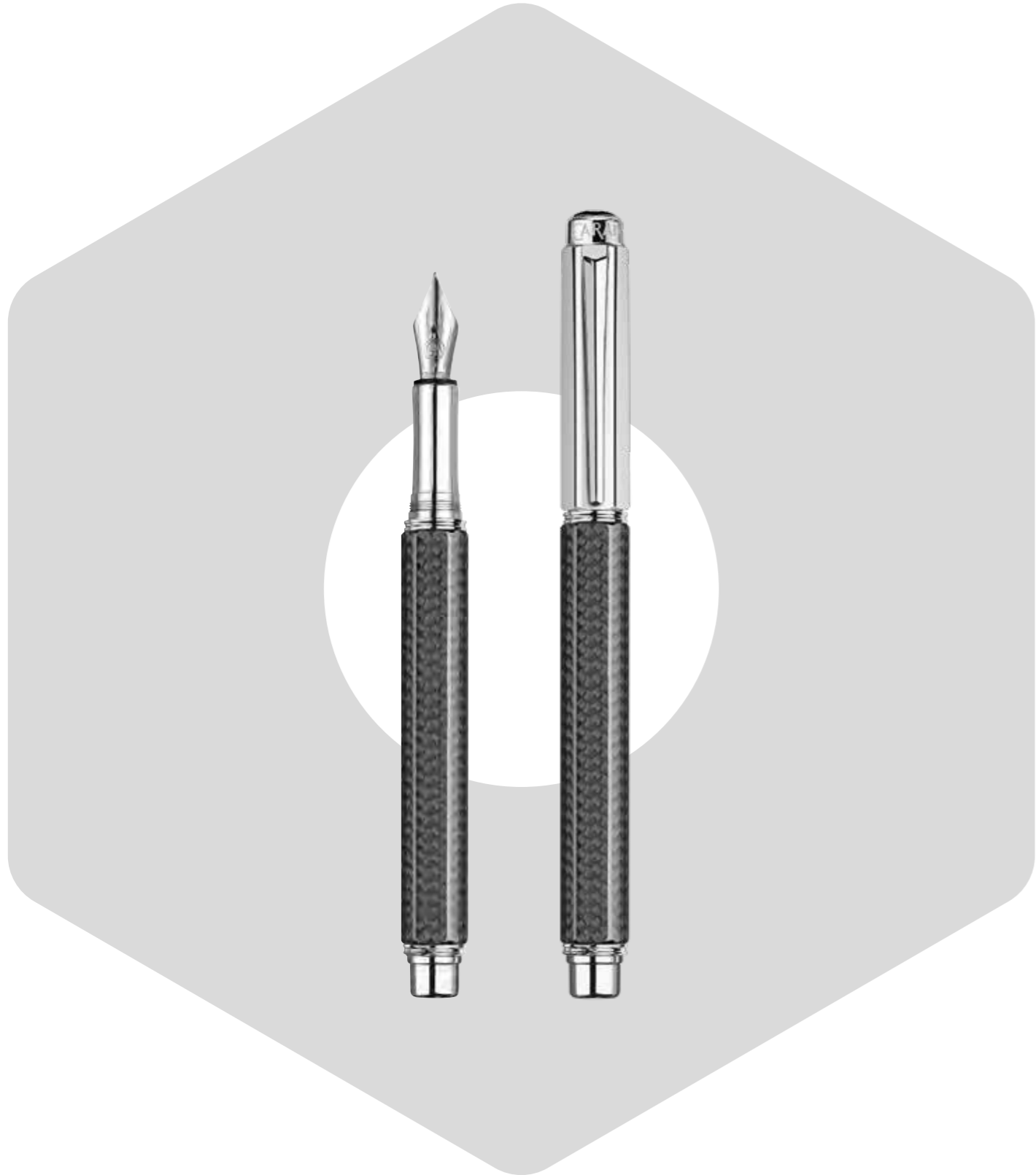

CARBON FIBRE

Carbon fibre is the epitome of a modern material. Its lightness and outstanding rigidity give it an immediate appeal and Caran d'Ache uses it to create a new, high-tech interpretation of tradition. Removed from its normal environment of top-level sports, and linked with silver-plated and rhodium-coated elements, carbon fibre brings power and strength to the Varius line.



VARIUS CARBON
SILVER-PLATED,
RHODIUM-COATED FINISH

FOUNTAIN PEN / M-4490.017

nib sizes: B - .027 / F - .007 / EF - .997 / OM - .987 / OB - .977
nib: 18 carat gold, rhodium-coated
Piston ink pump or ink cartridge
Cap: Screw
Refill: Ink and cartridges Chromatics Collection (p.140 -143)



VARIUS CARBON
SILVER-PLATED,
RHODIUM-COATED FINISH

ROLLER PEN / 4470.017

Cartridge
Cap: Screw
Refills: Roller cartridge, fine or medium, blue or black (p. 144)



VARIUS CARBON
SILVER-PLATED,
RHODIUM-COATED FINISH

BALLPOINT PEN / 4480.017

Cartridge
Mechanism: Push button
Refills: Goliath cartridge, large, medium or fine (p.144)



VARIUS CARBON
SILVER-PLATED,
RHODIUM-COATED FINISH

MECHANICAL PENCIL / 4460.017

0.7mm lead
Mechanism: Push button
Refills: 0.7 mm graphite leads, HB or B and replacement erasers (p.145)



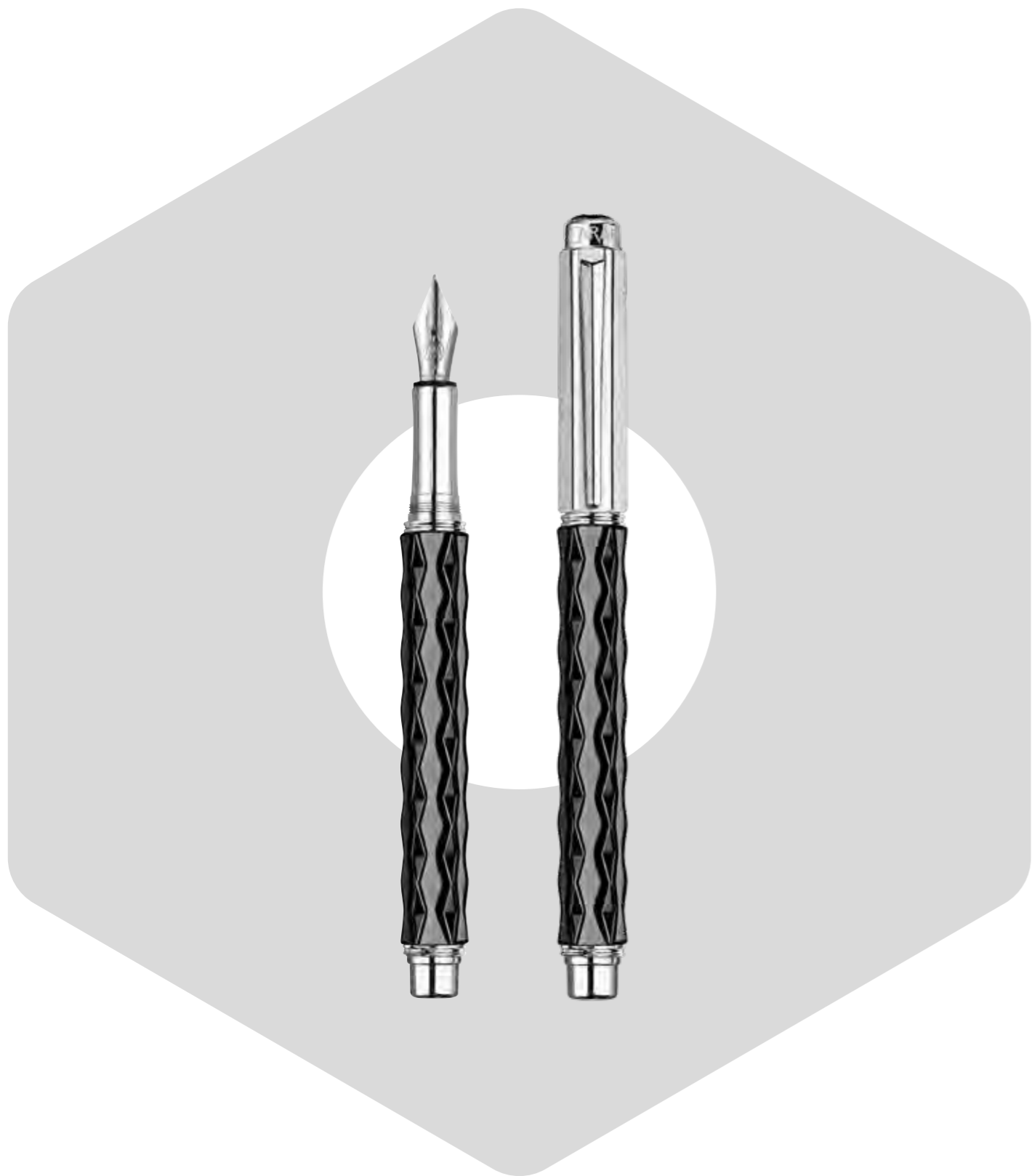

VARIUS CERAMIC BLACK
SILVER-PLATED,
RHODIUM-COATED FINISH

FOUNTAIN PEN / M-4490.109

nib sizes: B - .119 / F - .099
nib: 18 carat gold, rhodium-coated
Piston ink pump or ink cartridge
Cap: Screw
Refill: Ink and cartridges Chromatics Collection (p.140 -143)



VARIUS CERAMIC BLACK
SILVER-PLATED,
RHODIUM-COATED FINISH

ROLLER PEN / 4470.109

Cartridge
Cap: Screw
Refills: Roller cartridge, fine or medium, blue or black (p. 144)



VARIUS CERAMIC BLACK
SILVER-PLATED,
RHODIUM-COATED FINISH

BALLPOINT PEN / 4480.109

Cartridge
Mechanism: Push button
Refills: Goliath cartridge, large, medium or fine (p.144)



VARIUS CERAMIC BLACK
SILVER-PLATED,
RHODIUM-COATED FINISH

MECHANICAL PENCIL / 4460.109

0.7mm lead
Mechanism: Push button
Refills: 0.7 mm graphite leads, HB or B and replacement erasers (p.145)

CERAMIC

For the past few years, high-tech ceramic has been employed in the production of watchcases. This material is highly valued by the watchmakers for its lightness, its resistance to scratches and its silky touch. When associated with metal, ceramic offers a subtle contrast of materials and an elegant lighting effect.



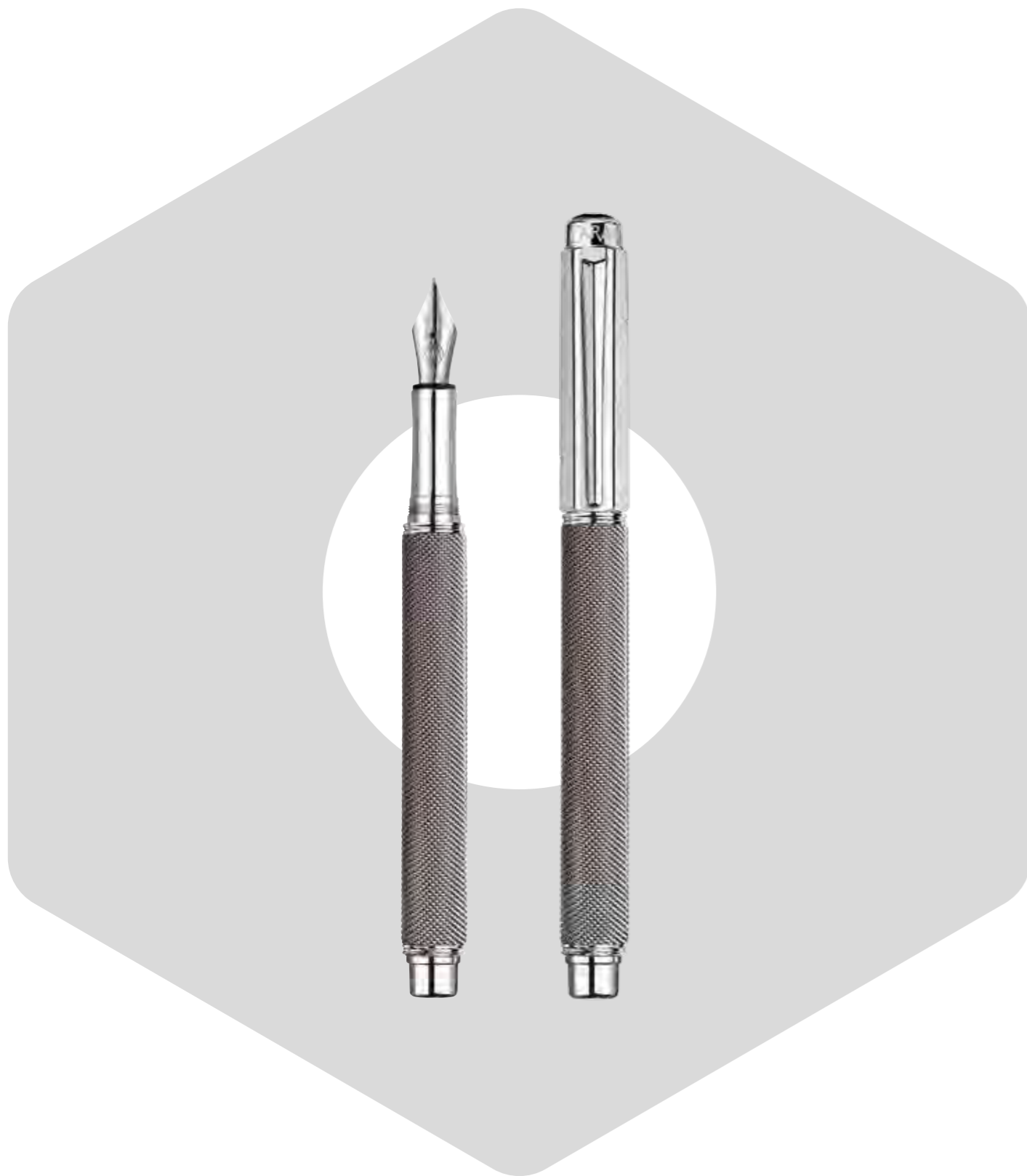

COAT OF MAIL

In its innovative use of coat of mail, Caran d'Ache has made the most of this legendary material that once protected medieval knights. Its woven links of stainless steel create a very pleasant texture in the writer's hand. Coat of mail even comes in a gold-plated version.



VARIUS IVANHOE
SILVER-PLATED,
RHODIUM-COATED FINISH

FOUNTAIN PEN / M-4490.014

nib sizes: B - .024 / F - .004 / EF - .994 / OM - .984 / OB - .974
nib: 18 carat gold, rhodium-coated
Piston ink pump or ink cartridge
Cap: Screw
Refill: Ink and cartridges Chromatics Collection (p.140 -143)



VARIUS IVANHOE
SILVER-PLATED,
RHODIUM-COATED FINISH

ROLLER PEN / 4470.014

Cartridge
Cap: Screw
Refills: Roller cartridge, fine or medium, blue or black (p. 144)



VARIUS IVANHOE
SILVER-PLATED,
RHODIUM-COATED FINISH

BALLPOINT PEN / 4480.014

Cartridge
Mechanism: Push button
Refills: Goliath cartridge, large, medium or fine (p.144)



VARIUS IVANHOE
SILVER-PLATED,
RHODIUM-COATED FINISH

MECHANICAL PENCIL / 4460.014

0.7mm lead
Mechanism: Push button
Refills: 0.7 mm graphite leads, HB or B and replacement erasers (p.145)



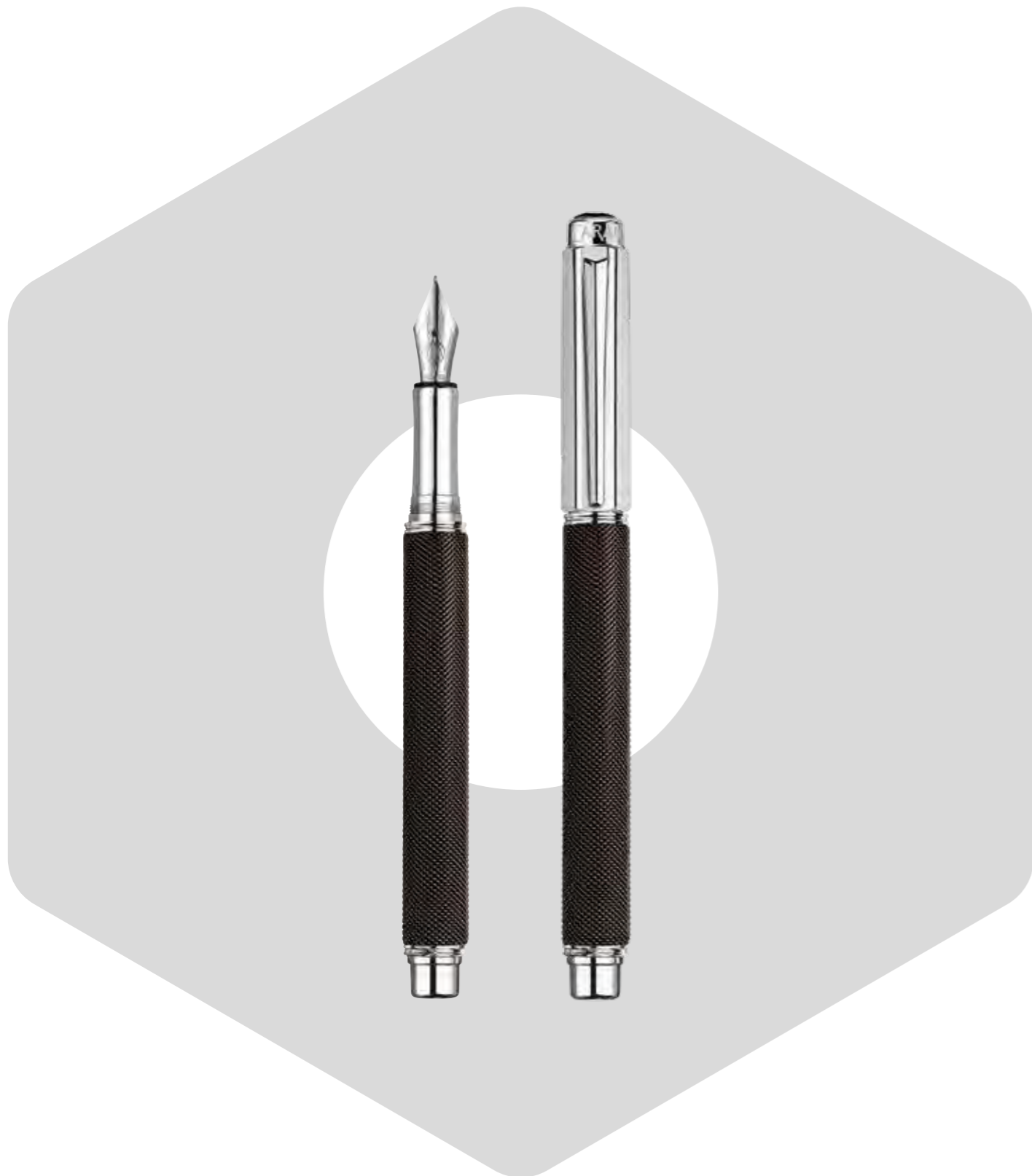

BLACK COAT OF MAIL

The body of the Varius Ivanhoe Black is covered in a micro-woven coat of mail in deep black stainless steel (a Milanese sheath). Using a highly advanced technology, Caran d'Ache craftsmen have treated the steel to receive a black PVD coating that is both strong and beautiful. This process colours the fundamental structure of the steel giving it an extraordinary fineness that will remain eternally unchanged.



VARIUS IVANHOE BLACK
SILVER-PLATED,
RHODIUM-COATED FINISH

FOUNTAIN PEN / M-4490.082

nib sizes: B - .092 / F -.072 / EF -.062 / OM - .052 / OB - .042
nib: 18 carat gold, rhodium-coated
Piston ink pump or ink cartridge
Cap: Screw
Refill: Ink and cartridges Chromatics Collection (p.140 -143)



VARIUS IVANHOE BLACK
SILVER-PLATED,
RHODIUM-COATED FINISH

ROLLER PEN / 4470.082

Cartridge
Cap: Screw
Refills: Roller cartridge, fine or medium, blue or black (p. 144)



VARIUS IVANHOE BLACK
SILVER-PLATED,
RHODIUM-COATED FINISH

BALLPOINT PEN / 4480.082

Cartridge
Mechanism: Push button
Refills: Goliath cartridge, large, medium or fine (p.144)



VARIUS IVANHOE BLACK
SILVER-PLATED,
RHODIUM-COATED FINISH

MECHANICAL PENCIL / 4460.082

0.7mm lead
Mechanism: Push button
Refills: 0.7 mm graphite leads, HB or B and replacement erasers (p.145)





LÉMAN

An expert in colours and media dedicated to the fine arts, Caran d'Ache also calls on all its talent to design writing instruments in exceptional colours. Since 1998, the Léman collection has embodied the wealth of chromatic variations illuminating the shores of the lake so dear to the inhabitants of Geneva. A veritable homage to the most beautiful shades that nature has to offer, the Léman collection combines stunningly coloured varnishes with the brilliance of precious metals. Hand polished by the company's craftsmen, these writing instruments can also be enhanced through traditional guillochage and lacquering know-how, offering an explosion of shades and curves. Caran d'Ache has enhanced its collection of Haute Ecriture Léman instruments with the Léman Slim range boasting a slender, refined outline for light and delicate writing comfort.

- Two collections: Léman & Léman Slim
- Four writing instruments per collection:
 - Fountain pen, roller pen, ballpoint pen and mechanical pencil
 - Body and cap made of thick gauge brass in different colours and finishes
 - Articulated clip, using a spring mechanism
 - Gold-plated or silver-plated, rhodium-coated finishes
 - Fountain pen nib in 18 carat gold, in four different widths: F, M, B, (BB – Léman only)
- Can be customised by means of personalised engraving
- Lifetime international guarantee
- Swiss Made

Underneath a layer of translucent lacquer, reminiscent of the intense blue of the ocean depths, delicate undulating reflections appear on the body of the Léman Grand Bleu.



THE CASE
LÉMAN

184 x 80 x 40 mm
Standard screen-printed case
Includes:
- the user guide / guarantee
- two small blue ink cartridges or one black F roller cartridge or a black M Goliath cartridge



LÉMAN GRAND BLEU
SILVER-PLATED,
RHODIUM-COATED FINISH

FOUNTAIN PEN / M - 4799.168

nib sizes: B -.178 / F -.158 / BB -.188
nib: 18 carat gold, rhodium-coated
Fountain pen – piston ink pump or ink cartridge
Cap: Screw
Refills: Ink and cartridges Chromatics Collection (p.140 -143)



LÉMAN GRAND BLEU
SILVER-PLATED,
RHODIUM-COATED FINISH

ROLLER PEN / 4779.168

Cartridge
Cap: Screw
Refills: Roller cartridge, fine or medium, blue or black (p. 144)



LÉMAN GRAND BLEU
SILVER-PLATED,
RHODIUM-COATED FINISH

BALLPOINT PEN / 4789.168

Cartridge
Mechanism: Rotary
Refills: Goliath cartridge, large, medium or fine (p.144)



LÉMAN GRAND BLEU
SILVER-PLATED,
RHODIUM-COATED FINISH

MECHANICAL PENCIL / 4769.168

0.7 mm graphite leads
Mechanism: Rotary
Refills: 0.7 mm graphite leads, HB or B and replacement erasers (p.145)



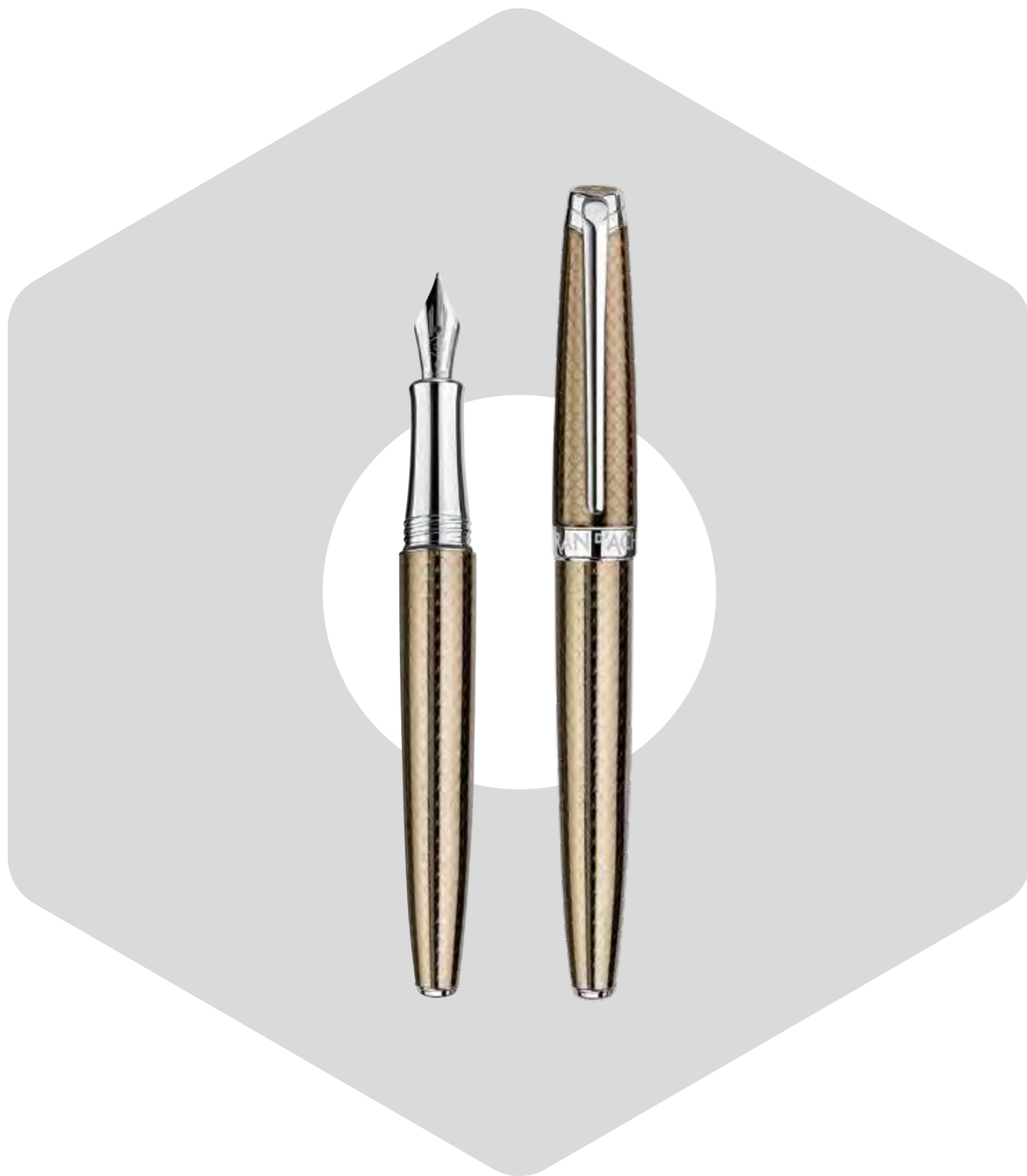

LÉMAN CAVIAR
SILVER-PLATED,
RHODIUM-COATED FINISH

FOUNTAIN PEN / M - 4799.497
nib sizes: B -.507 / F -.487 / BB -.517
nib: 18 carat gold, rhodium-coated
Fountain pen – piston ink pump or ink cartridge
Cap: Screw
Refills: Ink and cartridges Chromatics Collection (p.140 -143)



LÉMAN CAVIAR
SILVER-PLATED,
RHODIUM-COATED FINISH

ROLLER PEN / 4779.497
Ink cartridge
Cap: Screw
Refills: Roller cartridge, fine or medium, blue or black (p. 144)



LÉMAN CAVIAR
SILVER-PLATED,
RHODIUM-COATED FINISH

BALLPOINT PEN / 4789.497
Cartridge
Mechanism: Rotary
Refills: Goliath cartridge, large, medium or fine (p.144)



LÉMAN CAVIAR
SILVER-PLATED,
RHODIUM-COATED FINISH

MECHANICAL PENCIL / 4769.497
0.7 mm graphite leads
Mechanism: Rotary
Refills: 0.7 mm graphite leads, HB or B and replacement erasers (p.145)

The Léman Caviar, a subtle harmonisation of coating and guilloché techniques, reveals fine engraving beneath a transparent grey varnish, giving rise to some surprising metallised reflections.



LÉMAN EBONY BLACK
GOLD-PLATED FINISH

FOUTAIN PEN / M-4799.282

nib sizes: B -.292 / F -.272
Nib : 18 carat gold, gold plated
Piston ink pump or ink cartridge - Mechanism: Rotary
Refills: Ink and cartridges collection
Chromatics (voir p.140 -143)



LÉMAN EBONY BLACK
SILVER-PLATED,
RHODIUM-COATED FINISH

FOUTAIN PEN / M-4799.782

nib sizes: B - .792 / F - .772 / BB - .802
nib: 18 carat gold, rhodium-coated
Piston ink pump or ink cartridge - Cap: Screw
Refills: Ink and cartridges
Collection Chromatics (p.140 -143)

LACQUER

Lacquer is a precious, refined material that requires great care and attention in its application as well as its finishing. Polished repeatedly, it develops all its wonderful shine in the hands of a craftsman.



LÉMAN EBONY BLACK
GOLD-PLATED FINISH

ROLLER PEN / 4779.282

Ink cartridge
Cap: Screw
Refills: Roller cartridge, fine or medium, blue or black (p. 144)



LÉMAN EBONY BLACK
GOLD-PLATED FINISH

BALLPOINT PEN / 4789.282

Cartridge
Mechanism: Rotary
Refills: Goliath cartridge, large, medium or fine (p.144)



LÉMAN EBONY BLACK
GOLD-PLATED FINISH

MECHANICAL PENCIL / 4769.282

0.7mm lead
Mechanism: Rotary
Refills: 0.7 mm graphite leads, HB or B and replacement erasers (p.145)



LÉMAN EBONY BLACK
SILVER-PLATED, RHODIUM-COATED FINISH

ROLLER PEN / 4779.782

Cartridge
Cap: Screw
Refills: Roller cartridge, fine or medium, blue or black (p. 144)



LÉMAN EBONY BLACK
SILVER-PLATED,
RHODIUM-COATED FINISH

BALLPOINT PEN / 4789.782

Cartridge
Mechanism: Rotary
Refills: Goliath cartridge, large, medium or fine (p.144)



LÉMAN EBONY BLACK
SILVER-PLATED, RHODIUM-COATED FINISH

MECHANICAL PENCIL / 4769.782

0.7mm lead
Mechanism: Rotary
Refills: 0.7 mm graphite leads, HB or B and replacement erasers (p.145)



LÉMAN BLACK MATT
SILVER-PLATED,
RHODIUM-COATED FINISH

FOUNTAIN PEN / M-4799.496

nib sizes: B - .506 / F - .486 / BB - .516
nib: 18 carat gold, rhodium-coated
Piston ink pump or ink cartridge - Cap: Screw
Refills: Ink and cartridges collection
Chromatics (voir p.140-143)



LÉMAN BLUE MATT
SILVER-PLATED,
RHODIUM-COATED FINISH

FOUNTAIN PEN / M-4799.449

nib sizes: B - .459 / F - .439 / BB .469
nib: 18 carat gold, rhodium-coated
Piston ink pump or ink cartridge - Cap: Screw
Refills: Ink and cartridges collection
Chromatics (voir p.140-143)

LACQUER

Lacquer is a precious, refined material that requires great care and attention in its application as well as its finishing. Polished repeatedly, it develops all its wonderful shine in the hands of a craftsman.



LÉMAN BLACK MATT
SILVER-PLATED,
RHODIUM-COATED FINISH

ROLLER PEN / 4779.496

Cartridge
Cap: Screw
Refills: Roller cartridge, fine or medium, blue or black (p. 144)



LÉMAN BLACK MATT
SILVER-PLATED, RHODIUM-COATED FINISH

BALLPOINT PEN / 4789.496

Cartridge
Mechanism: Rotary
Refills: Goliath cartridge, large, medium or fine (p.144)



LÉMAN BLACK MATT
SILVER-PLATED,
RHODIUM-COATED FINISH

MECHANICAL PENCIL / 4769.496

0.7mm lead
Mechanism: Rotary
Refills: 0.7 mm graphite leads, HB or B and replacement erasers (p.145)



LÉMAN BLUE MATT
SILVER-PLATED,
RHODIUM-COATED FINISH

ROLLER PEN / 4779.449

Cartridge
Cap: Screw
Refills: Roller cartridge, fine, blue or black (p. 144)



LÉMAN BLUE MATT
SILVER-PLATED,
RHODIUM-COATED FINISH

BALLPOINT PEN / 4789.449

Cartridge
Mechanism: Rotary
Refills: Goliath cartridge, large, medium or fine (p.144)



LÉMAN BLUE MATT
SILVER-PLATED,
RHODIUM-COATED FINISH

MECHANICAL PENCIL / 4769.449

0.7mm lead
Mechanism: Rotary
Refills: 0.7 mm graphite leads, HB or B and replacement erasers (p.145)



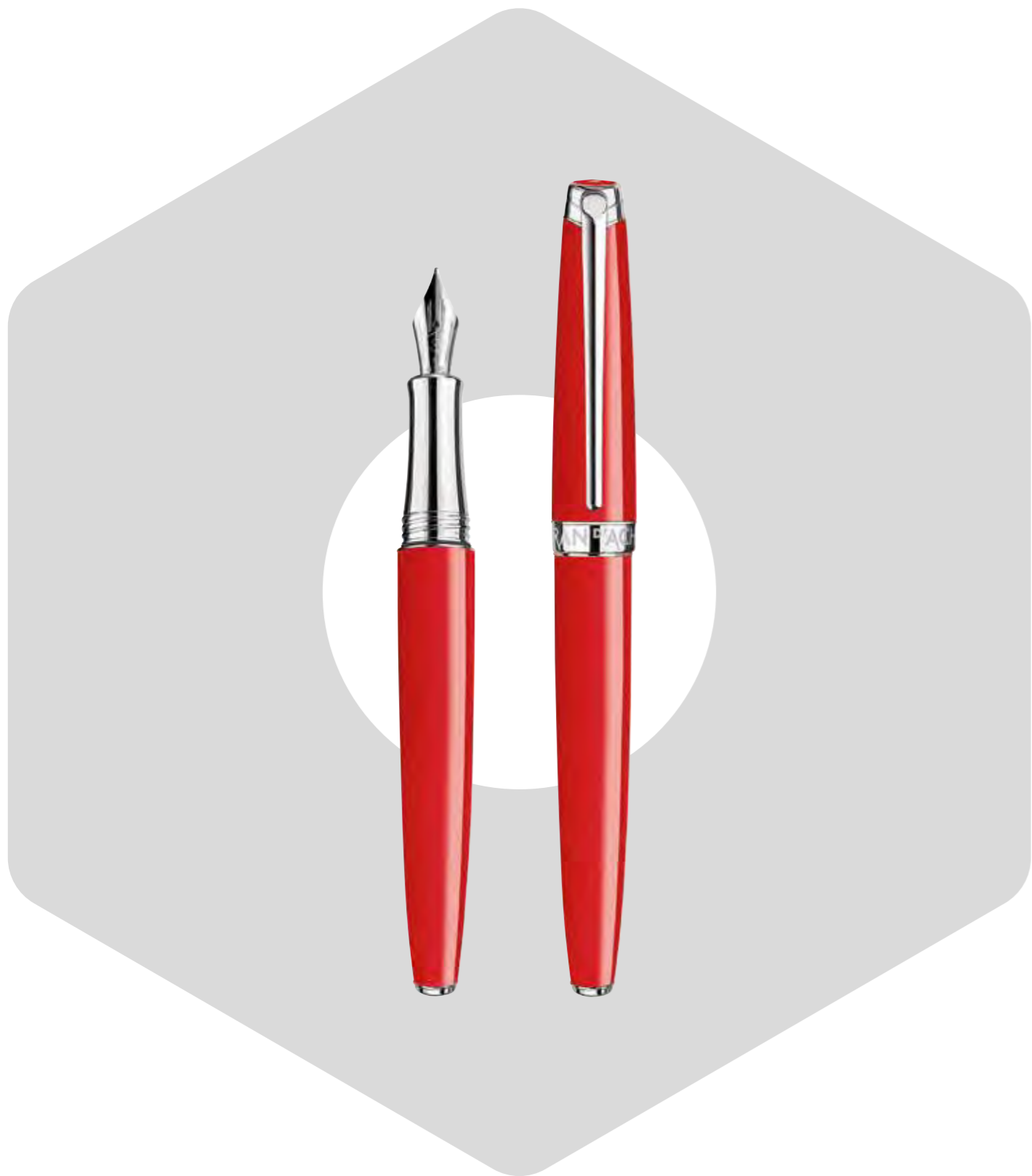

LÉMAN RED
SILVER-PLATED,
RHODIUM-COATED FINISH

FOUNTAIN PEN / M - 4799.770

nib sizes: B - .780 / F - .760 / BB - .790
 nib: 18 carat gold, rhodium-coated
 Fountain pen – piston ink pump or ink cartridge
 Cap: Screw
 Refills: Ink and cartridges Chromatics Collection (p.140 -143)



LÉMAN RED
SILVER-PLATED,
RHODIUM-COATED FINISH

ROLLER PEN / 4779.770

Cartridge
 Cap: Screw
 Refills: Roller cartridge, fine or medium, blue or black (p. 144)



LÉMAN RED
SILVER-PLATED,
RHODIUM-COATED FINISH

BALLPOINT PEN / 4789.770

Cartridge
 Mechanism: Rotary
 Refills: Goliath cartridge, large, medium or fine (p.144)



LÉMAN RED
SILVER-PLATED,
RHODIUM-COATED FINISH

MECHANICAL PENCIL / 4769.770

0.7mm lead
 Mechanism: Rotary
 Refills: 0.7 mm graphite leads, HB or B and replacement erasers (p.145)

LACQUER

Lacquer is a precious, refined material that requires great care and attention in its application as well as its finishing. Polished repeatedly, it develops all its wonderful shine in the hands of a craftsman.



LÉMAN BICOLOR BLACK
SILVER-PLATED,
RHODIUM-COATED FINISH

FOUTAIN PEN / M-4799.289

nib sizes: B - .299 / F - .279 / BB - .309
nib: 18 carat gold, rhodium-coated
Piston ink pump or ink cartridge - Cap: Screw
Refills: Ink and cartridges collection
Chromatics (voir p.140 -143)



LÉMAN BICOLOR WHITE
SILVER-PLATED,
RHODIUM-COATED FINISH

FOUTAIN PEN / M-4799.001

nib sizes: B - .011 / F - .991 / BB - .021
nib: 18 carat gold, rhodium-coated
Piston ink pump or ink cartridge - Cap: Screw
Refills: Ink and cartridges collection
Chromatics (voir p.140 -143)

LACQUER

Lacquer is a precious, refined material that requires great care and attention in its application as well as its finishing. Polished repeatedly, it develops all its wonderful shine in the hands of a craftsman.



LÉMAN BICOLOR BLACK
SILVER-PLATED,
RHODIUM-COATED FINISH

ROLLER PEN / 4779.289

Cartridge
Cap: Screw
Refills: Roller cartridge, fine or medium, blue or black (p. 144)



LÉMAN BICOLOR BLACK
SILVER-PLATED,
RHODIUM-COATED FINISH

BALLPOINT PEN / 4789.289

Cartridge
Mechanism: Rotary
Refills: Goliath cartridge, large, medium or fine (p.144)



LÉMAN BICOLOR BLACK
SILVER-PLATED,
RHODIUM-COATED FINISH

MECHANICAL PENCIL / 4769.289

0.7mm lead
Mechanism: Rotary
Refills: 0.7 mm graphite leads, HB or B and replacement erasers (p.145)



LÉMAN BICOLOR WHITE
SILVER-PLATED,
RHODIUM-COATED FINISH

ROLLER PEN / 4779.001

Cartridge
Cap: Screw
Refills: Roller cartridge, fine or medium, blue or black (p. 144)



LÉMAN BICOLOR WHITE
SILVER-PLATED,
RHODIUM-COATED FINISH

BALLPOINT PEN / 4789.001

Cartridge
Mechanism: Rotary
Refills: Goliath cartridge, large, medium or fine (p.144)



LÉMAN BICOLOR WHITE
SILVER-PLATED,
RHODIUM-COATED FINISH

MECHANICAL PENCIL / 4769.001

0.7mm lead
Mechanism: Rotary
Refills: 0.7 mm graphite leads, HB or B and replacement erasers (p.145)



LÉMAN BICOLOR SAFFRON
SILVER-PLATED,
RHODIUM-COATED FINISH

FOUNTAIN PEN / M-4799.530

nib sizes: B - .540 / F - .520 / BB - .550
nib: 18 carat gold, rhodium-coated
Piston ink pump or ink cartridge - Cap: Screw
Refills: Ink and cartridges collection
Chromatics (voir p.140-143)



LÉMAN BICOLOR TURQUOISE
SILVER-PLATED,
RHODIUM-COATED FINISH

FOUNTAIN PEN / M-4799.171

nib sizes: B - .181 / F - .161 / BB - .191
nib: 18 carat gold, rhodium-coated
Piston ink pump or ink cartridge - Cap: Screw
Refills: Ink and cartridges collection
Chromatics (voir p.140-143)

LACQUER

Lacquer is a precious, refined material that requires great care and attention in its application as well as its finishing. Polished repeatedly, it develops all its wonderful shine in the hands of a craftsman.



LÉMAN BICOLOR SAFFRON
SILVER-PLATED,
RHODIUM-COATED FINISH

ROLLER PEN / 4779.530

Cartridge
Mechanism: Rotary
Refills: Roller cartridge, fine or medium, blue or black (p. 144)



LÉMAN BICOLOR SAFFRON
SILVER-PLATED,
RHODIUM-COATED FINISH

BALLPOINT PEN / 4789.530

Cartridge
Mechanism: Rotary
Refills: Goliath cartridge, large, medium or fine (p.144)



LÉMAN BICOLOR SAFFRON
SILVER-PLATED,
RHODIUM-COATED FINISH

MECHANICAL PENCIL / 4769.530

0.7mm lead
Mechanism: Rotary
Refills: 0.7 mm graphite leads, HB or B and replacement erasers (p.145)



LÉMAN BICOLOR TURQUOISE
SILVER-PLATED,
RHODIUM-COATED FINISH

ROLLER PEN / 4779.171

Cartridge
Cap: Screw
Refills: Roller cartridge, fine or medium, blue or black (p. 144)



LÉMAN BICOLOR TURQUOISE
SILVER-PLATED,
RHODIUM-COATED FINISH

BALLPOINT PEN / 4789.171

Cartridge
Mechanism: Rotary
Refills: Goliath cartridge, large, medium or fine (p.144)



LÉMAN BICOLOR TURQUOISE
SILVER-PLATED,
RHODIUM-COATED FINISH

MECHANICAL PENCIL / 4769.171

0.7mm lead
Mechanism: Rotary
Refills: 0.7 mm graphite leads, HB or B and replacement erasers (p.145)



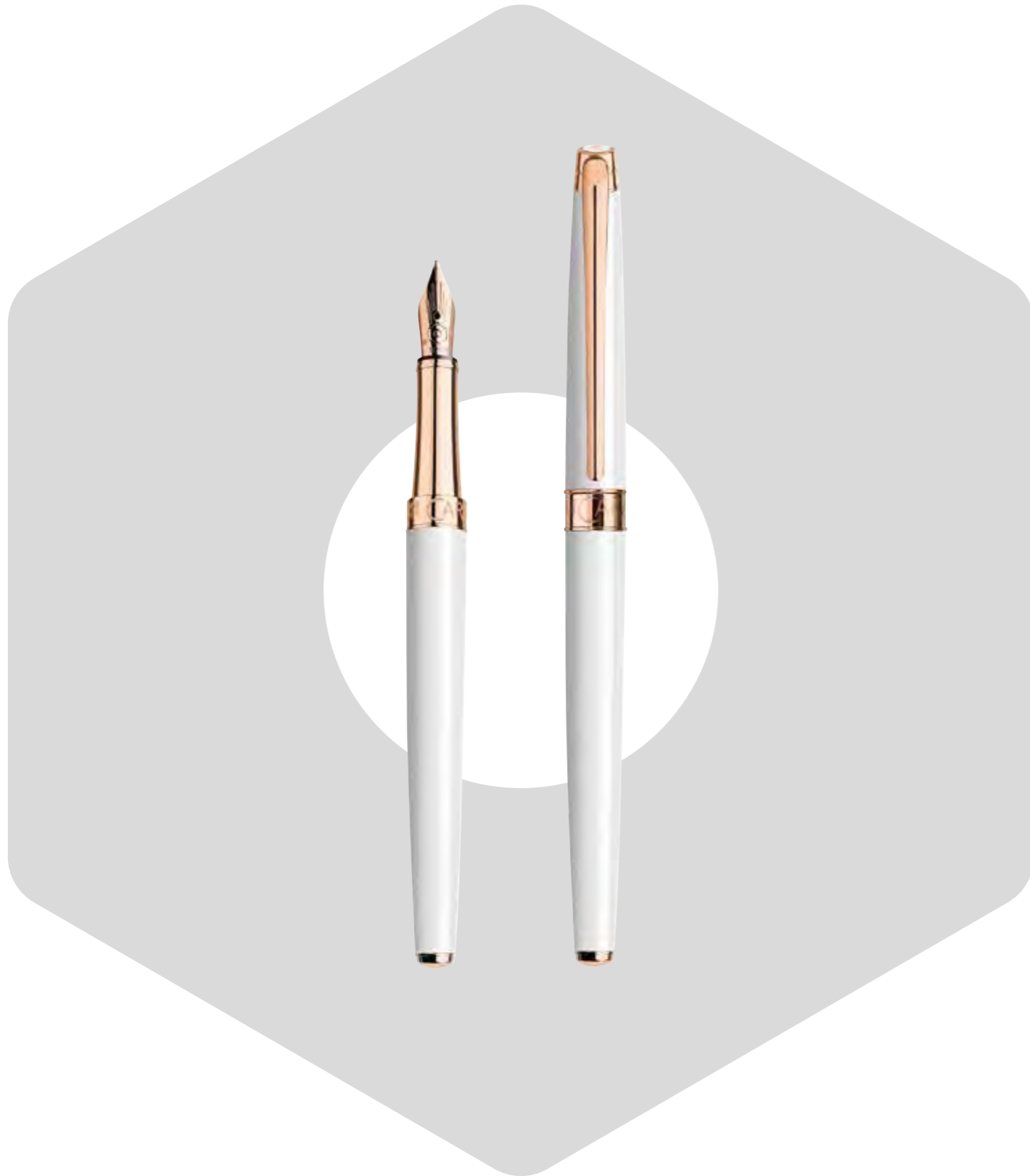

LÉMAN SLIM WHITE
PINK GOLD-PLATING FINISH

FOUNTAIN PEN / M- 4791.001

nib sizes: B - .011 / F - .991
nib: 18 carat gold, rose-gold plated
Piston ink pump or ink cartridge
Cap: Click-in
Refills: Ink and cartridges Chromatics Collection (p.140 - 143)



LÉMAN SLIM WHITE
PINK GOLD-PLATING FINISH

ROLLER PEN / 4771.001

Cartridge
Cap: Click-in
Refills: Roller cartridge, fine or medium, blue or black (p. 144)



LÉMAN SLIM WHITE
PINK GOLD-PLATING FINISH

BALLPOINT PEN / 4781.001

Cartridge
Mechanism: Rotary
Refills: Goliath cartridge, large, medium or fine (p.144)



LÉMAN SLIM WHITE
PINK GOLD-PLATING FINISH

MECHANICAL PENCIL / 4761.001

0.7mm lead
Mechanism: Rotary
Refills: 0.7 mm graphite leads, HB or B and replacement erasers (p.145)

LACQUER

Lacquer is a precious, refined material that requires great care and attention in its application as well as its finishing. Polished repeatedly, it develops all its wonderful shine in the hands of a craftsman.



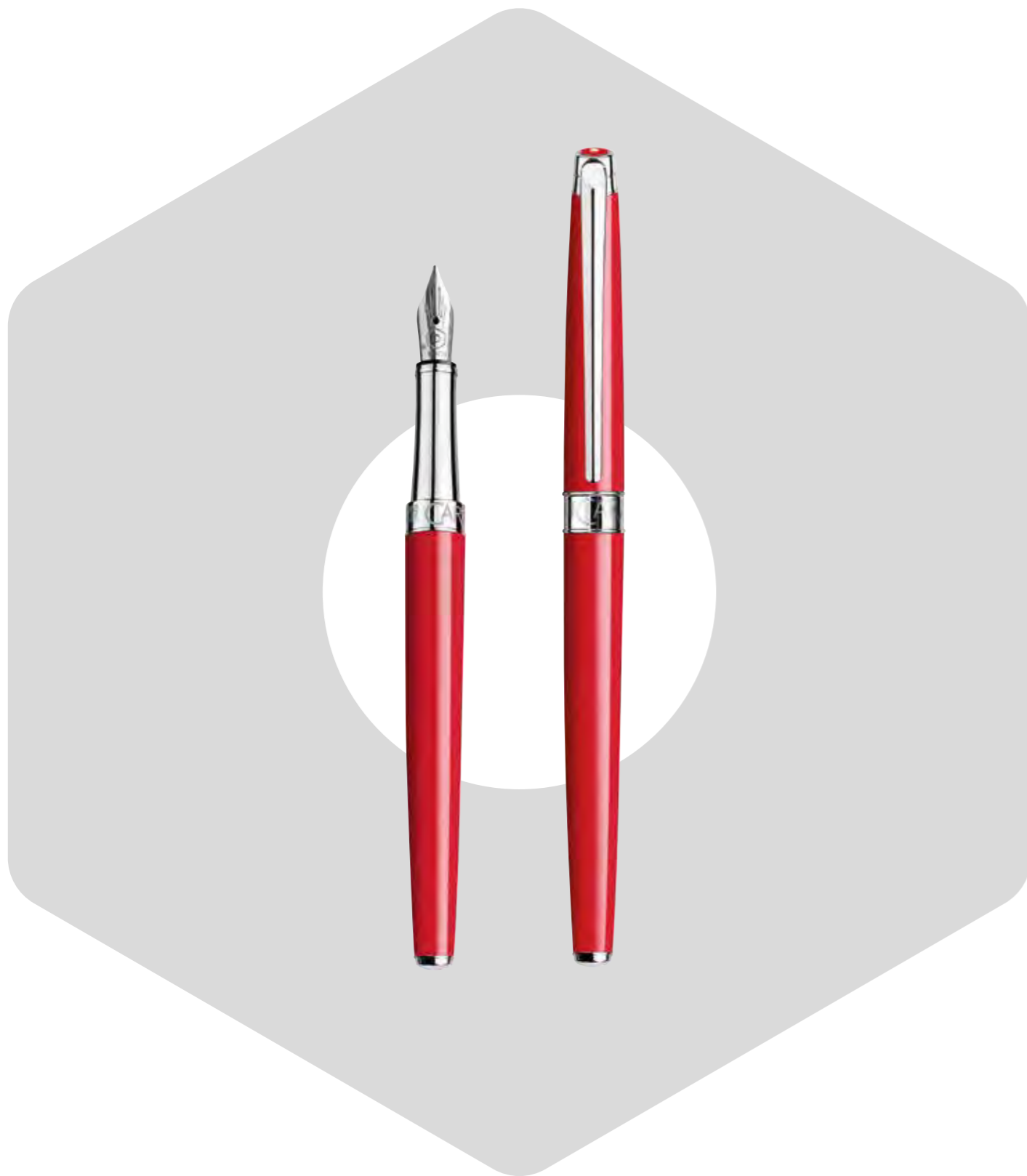

LÉMAN SLIM RED
SILVER-PLATED,
RHODIUM-COATED FINISH

FOUNTAIN PEN / M - 4791.770
nib sizes: B - .780 / F - .760
nib: 18 carat gold, rhodium-coated
Piston ink pump or ink cartridge
Cap: Click-in
Refills: Ink and cartridges Chromatics Collection (p.140 - 143)



LÉMAN SLIM RED
SILVER-PLATED,
RHODIUM-COATED FINISH

ROLLER PEN / 4771.770
Cartridge
Cap: Click-in
Refills: Roller cartridge, fine or medium, blue or black (p. 144)



LÉMAN SLIM RED
SILVER-PLATED,
RHODIUM-COATED FINISH

BALLPOINT PEN / 4781.770
Cartridge
Cap: Click-in
Refills: Goliath cartridge, large, medium or fine (p. 144)



LÉMAN SLIM RED
SILVER-PLATED,
RHODIUM-COATED FINISH

MECHANICAL PENCIL / 4761.770
0.7mm lead
Mechanism: Rotary
Refills: 0.7mm graphite leads, HB or B and replacement erasers (p. 145)

LACQUER

Lacquer is a precious, refined material that requires great care and attention in its application as well as its finishing. Polished repeatedly, it develops all its wonderful shine in the hands of a craftsman.



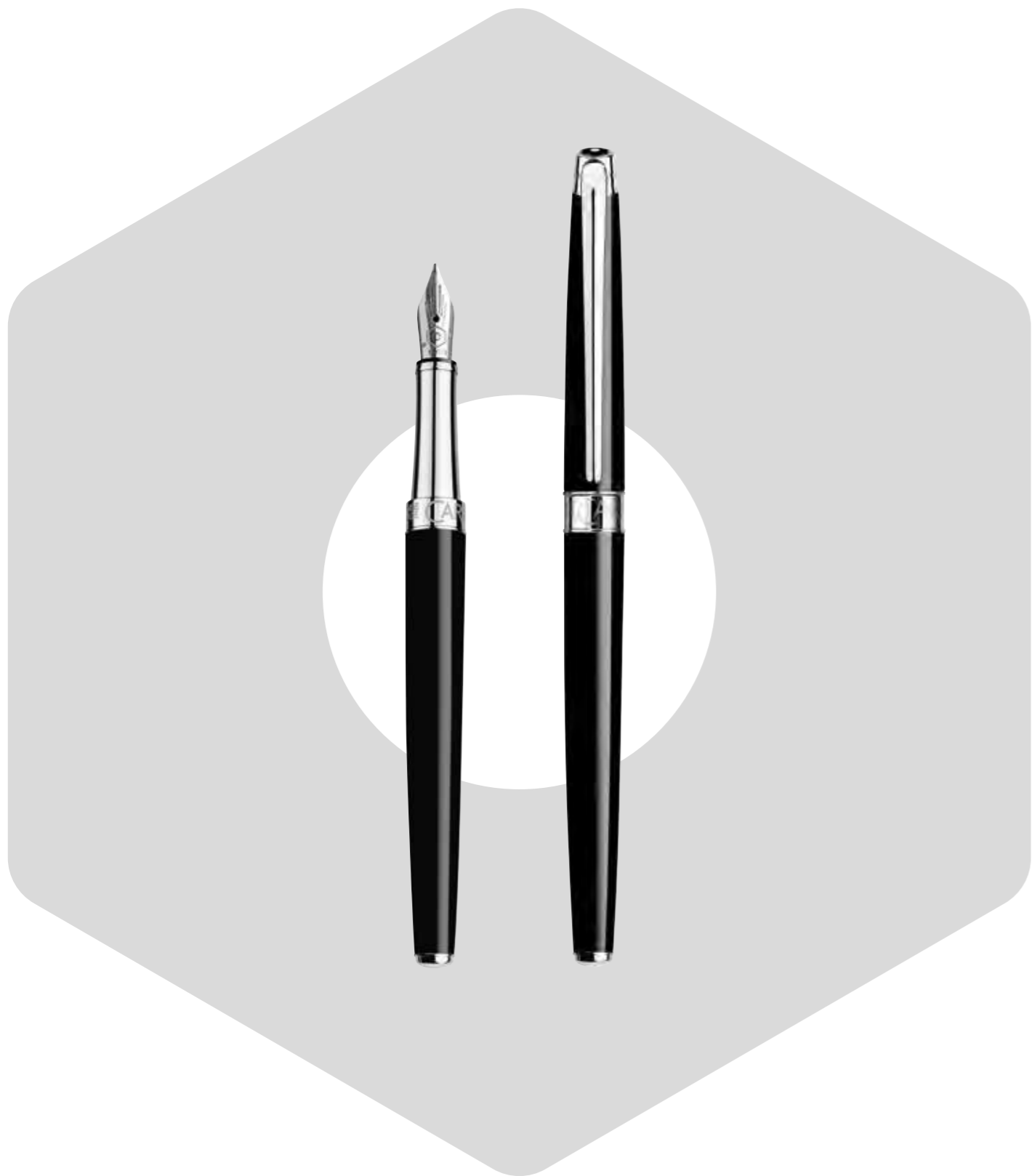

LÉMAN SLIM BLACK
SILVER-PLATED,
RHODIUM-COATED FINISH

FOUNTAIN PEN / M - 4791.782

nib sizes: B - .792 / F - .772
nib: 18 carat gold, rhodium-coated
Piston ink pump or ink cartridge
Cap: Click-in
Refills: Ink and cartridges Chromatics Collection (p.140 - 143)



LÉMAN SLIM BLACK
SILVER-PLATED,
RHODIUM-COATED FINISH

ROLLER PEN / 4771.782

Cartridge
Cap: Click-in
Refills: Roller cartridge, fine or medium, blue or black (p. 144)



LÉMAN SLIM BLACK
SILVER-PLATED,
RHODIUM-COATED FINISH

BALLPOINT PEN / 4781.782

Cartridge
Cap: Click-in
Refills: Goliath cartridge, large, medium or fine (p. 144)



LÉMAN SLIM BLACK
SILVER-PLATED,
RHODIUM-COATED FINISH

MECHANICAL PENCIL / 4761.782

0.7mm lead
Mechanism: Rotary
Refills: 0.7mm graphite leads, HB or B and replacement erasers (p. 145)

LACQUER

Lacquer is a precious, refined material that requires great care and attention in its application as well as its finishing. Polished repeatedly, it develops all its wonderful shine in the hands of a craftsman.



RNX.316

When Fine Writing instruments adopt high technology the result is the birth of a unique collection: RNX.316. In its name, RNX indicates its combination of two body shapes: Round and heXagonal. These are emblematic of the Caran d'Ache collections – easy to hold in the fingers for precise control of handwriting – in a new design that is immediately appealing. 316 refers to its stainless steel, a strong corrosion-resistant material that is enhanced by a pure, polished finish to give the Fine Writing instrument an elegance that will last a lifetime.

The RNX.316 incorporates the latest technical developments in Caran d'Ache expertise, making it one of the most distinctly modern of all writing instruments.

- Six writing instruments:
 - Fountain pen, roller pen, ballpoint pen, mechanical pencil, artist's mechanical pencil, multi-function
 - Body and cap made of steel 316L, polished or black PVD finish
 - Flexible clip
 - Innovative system for changing the ink cartridge
 - Ingenious "click-in" system for closing the pen
 - Steel nib coated in black PVD (sizes F, M, B)
 - Strong material/contemporary design
- Can be customised by means of personalised engraving
- Lifetime international guarantee
- Swiss Made





316L STAINLESS STEEL

The high-strength, stainless steel of the RNX. 316 collection guarantees that the writing instrument can withstand the stresses of repeated use. Its mechanical properties are complemented by its purity, created by precision polishing that immediately catches the eye. Its hardness produces incomparable writing comfort thanks to a fountain pen nib that is also composed of stainless steel.

BLACK PVD COATING

In the PVD technique, the ceramic is applied by a physical vapor deposition process which gives it optimal adherence; a cutting-edge technique for these pens that, with their laser engraving, demonstrate innovation across the whole line. The stainless steel nib of the fountain pen is also treated by the PVD process which results in remarkable fluidity and writing comfort.



RNX.316 PVD BLACK VERSION
BLACK PVD FINISH

FOUNTAIN PEN / 4590.080

nib sizes: B - .090 / F - .070
nib: Steel black PVD-coated
Innovative system for changing the cartridge
Cap: Ingenious «click-in» system for closing the pen
Refills: Ink and cartridges Chromatics Collection (p.140 -143)



RNX.316 PVD BLACK VERSION
BLACK PVD FINISH

ROLLER PEN / 4570.080

Innovative system for changing the cartridge
Cap: Ingenious «click-in» system for closing the pen
Refills: Roller cartridge, fine or medium, blue or black (p. 144)



RNX.316 PVD BLACK VERSION
BLACK PVD FINISH

BALLPOINT PEN / 4580.080

Cartridge
Mechanism: Push button
Refills: Goliath cartridge, large, medium or fine (p.144)



RNX.316 PVD BLACK VERSION
BLACK PVD FINISH

MECHANICAL PENCIL / 4560.080

0.7 mm lead
Mechanism: Push button
Refills: 0.7 mm graphite leads, HB or B and replacement erasers (p. 145)



RNX.316 PVD BLACK VERSION
BLACK PVD FINISH

MECHANICAL PENCIL ARTISTE / 4562.080

2mm lead
Mechanism: Push button
Refills: 2 mm Artist colour leads and eraser (p.145)



THE CASE
RNX.316

184 x 80 x 40 mm
Standard screen-printed case
Includes:
- the user guide /guarantee
- two small blue ink cartridges or one black F roller cartridge or a black M Goliath cartridge



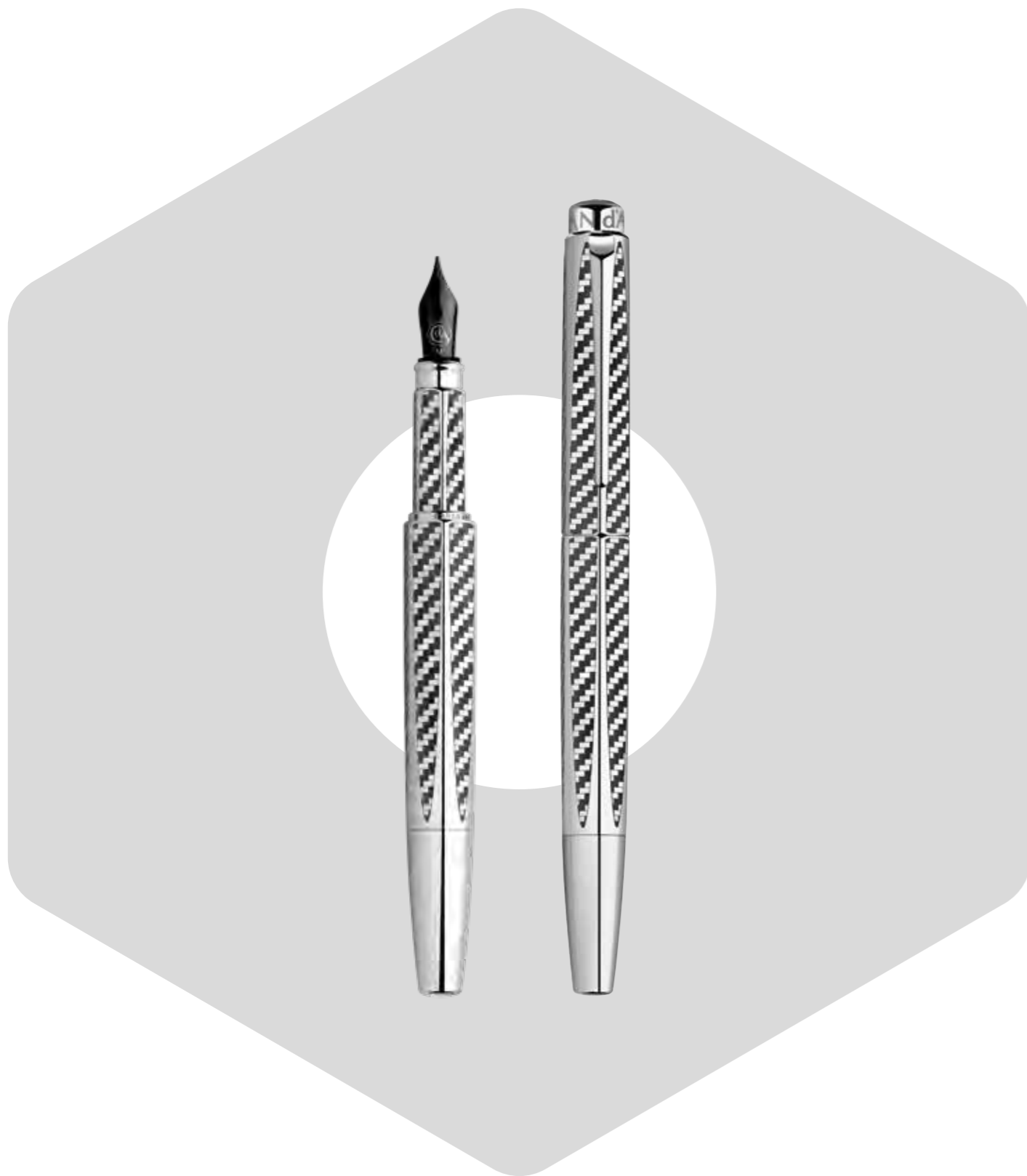

316L STAINLESS STEEL

The high-strength, stainless steel of the RNX. 316 collection guarantees that the writing instrument can withstand the stresses of repeated use. Its mechanical properties are complemented by its purity, created by precision polishing that immediately catches the eye. Its hardness produces incomparable writing comfort thanks to a fountain pen nib that is also composed of stainless steel.

LASER ENGRAVING

Inspired by carbon fibre, the RNX.316 Fiber design weaves and dances whilst laser strength and precision make the engraving sublime. Different shades of colour are created by varying the intensity of the laser beam. Combining technology and design, this writing instrument is finished in polished steel that contrasts with the matte ornamentation. The black, PVD-treated stainless steel nib is available in three different widths. This highly technical design item is confident and modern.



RNX.316 FIBER VERSION
POLISHED STEEL FINISH

FOUNTAIN PEN / M - 4590.083

nib sizes: B - .093 / F - .073
 nib: Steel black PVD-coated
 Fountain pen – Innovative system for changing the cartridge
 Cap: Ingenious «click-in» system for closing the pen
 Refills: Ink and cartridges Chromatics Collection (p.140 -143)



RNX.316 FIBER VERSION
POLISHED STEEL FINISH

ROLLER PEN / 4570.083

Innovative system for changing the cartridge
 Cap: Ingenious «click-in» system for closing the pen
 Refills: Roller cartridge, fine or medium, blue or black (p. 144)



RNX.316 FIBER VERSION
POLISHED STEEL FINISH

BALLPOINT PEN / 4580.083

Cartridge
 Mechanism: Push button
 Refills: Goliath cartridge, large, medium or fine (p.144)



RNX.316 FIBER VERSION
POLISHED STEEL FINISH

MECHANICAL PENCIL / 4560.083

0.7 mm lead
 Mechanism: Push button
 Refills: 0.7 mm graphite leads, HB or B and replacement erasers (p. 145)



RNX.316

MULTIFONCTION

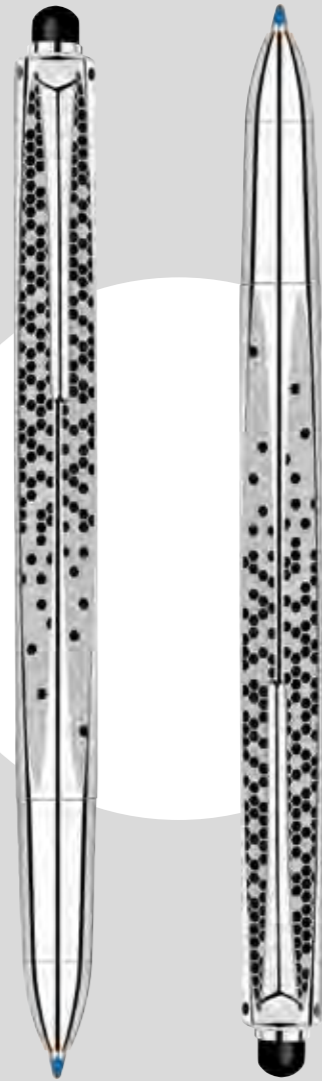

RNX.316 MULTIFONCTION
POLISHED STEEL FINISH

BALLPOINT PEN / 4583.082

3 cartridges (blue, black and red)
Mechanism: Push button
Refills: RNX.316 MULTIFONCTION
cartridges in 3 colours (blue, black and red) (p. 145)



THE CASE
RNX.316 MULTIFONCTION

184 x 80 x 40 mm
Standard screen-printed case
Includes:
- the user guide /guarantee& the RNX.316 user guide
- 5 cartridge (2 blue, 2 black, 1 red)
- 2 end pieces for touch screens (iPad, iPhone, Samsung Galaxy)

The RNX.316 Multifunction is both an elegant writing instrument and a high-tech tool. It comes equipped with three interchangeable cartridges in blue, black and red thanks to an ingenious twist system. A touch screen stylus is also included, allowing you to move from paper to digital in a single gesture. Stainless steel 316L body with engraving inspired by a pixelated screen.





ECRIDOR

Since the 1930s, the Ecridor writing instruments have been emblematic of the precious know-how of Caran d'Ache. Their sober and elegant hexagonal design is inspired by the shape of the pencils so dear to the Geneva-based company. The play of light and sparkle created by the perfect geometry of the symbols, so intense and inspiring, reflects the expertise of the master guillocheurs and polishers who give free rein to their talent. Whatever the metal covering the brass body and whatever the form (fountain pen, roller pen, ballpoint pen or mechanical pencil) and finely-engraved pattern on the instrument, there is an Ecridor to inspire each and every one of you.

- Four writing instruments:
 - Fountain pen, roller pen, ballpoint pen, mechanical pencil
 - Silver, rhodium, palladium and gold plated attributes
 - Flexible clip
 - Steel nib available in three distinct widths: F, M, B
- Can be customised by means of personalised engraving
- International lifetime guarantee
- Made in Switzerland

ECRIDOR FLOWERS



ECRIDOR FLOWERS
PALLADIUM FINISH

BALLPOINT PEN / 890.017

Mechanism: Push button
Refills: Goliath cartridge, large, medium of fine (p. 144)



THE CASE
ECRIDOR FLOWERS

184 x 80 x 40 mm
Standard screen-printed case
Includes:
- the user guide / guarantee
- a black Goliath M cartridge

The Maison Caran d'Ache presents Ecridor Flowers, inspired by the poetry of exotic gardens. Thanks to the expertise of artisans from the Swiss Manufacture, a luxuriant, heavenly natural environment places its radiant stamp on these emblematic Haute Ecriture writing instruments. Since its creation in 1930, Ecridor by the Maison Caran d'Ache has celebrated the art of engraving on the hexagonal bodies of these iconic writing instruments. The master-craftsmen at the Geneva Manufacture apply their talent to unremittingly innovative techniques. The motifs displayed on the models in this emblematic collection reveal a series of universes that are inspiring, timeless, sophisticated and elegant. For the first time, Caran d'Ache combines two engraving techniques to create the plant motifs of which Ecridor Flowers is composed. Using a laser, the designs of leaves and petals are outlined with exceptional precision and delicate whiteness on the body of the ballpoint pen. The three different sizes of the stamens within the exotic flowers produces the radiance of precious stones.

The young Swiss tennis player, Belinda Bencic, who is a Caran d'Ache ambassador, stylishly embodies the new Ecridor Flowers.



ECRIDOR GRAIN D'ORGE

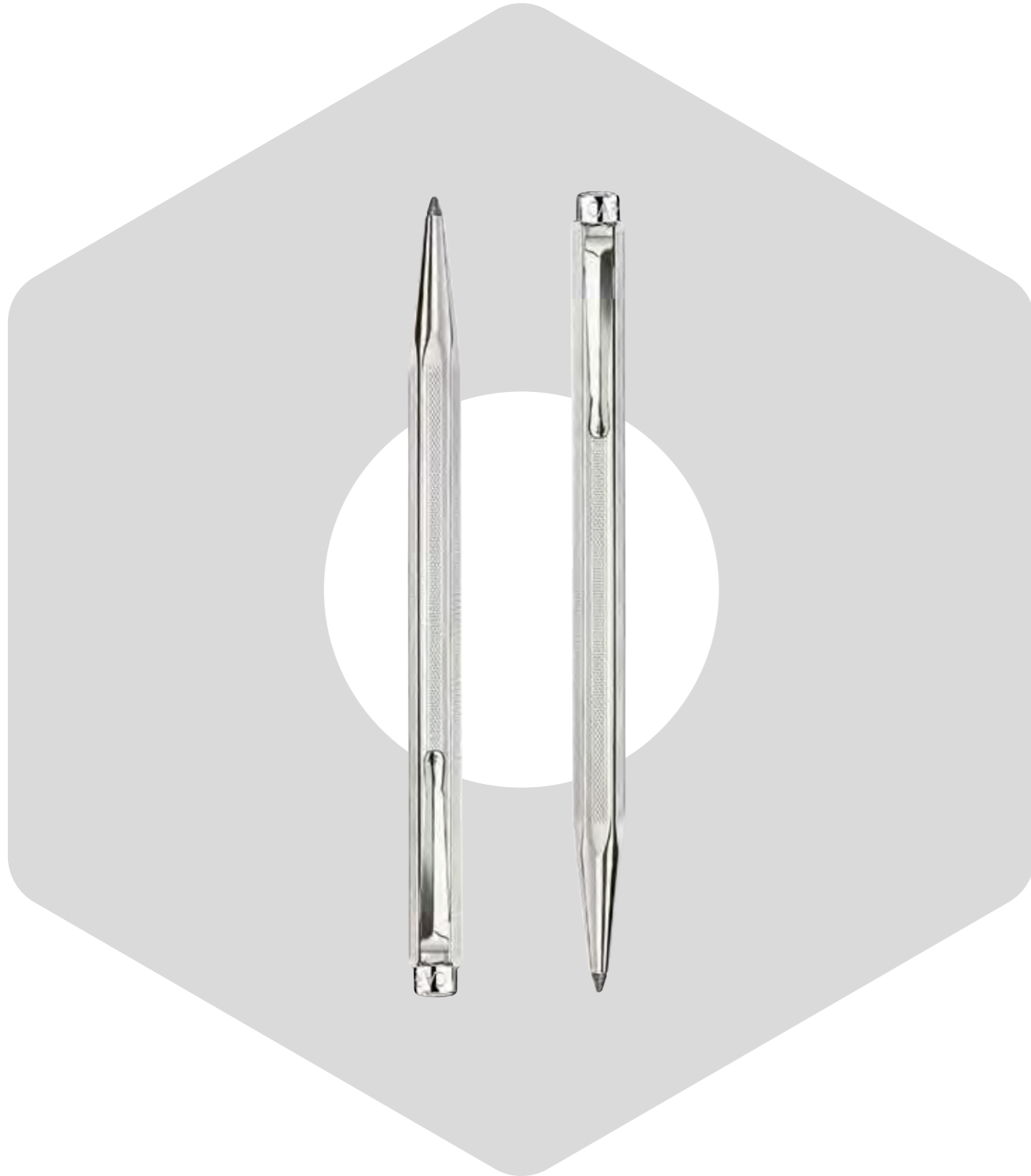

ECRIDOR GRAIN D'ORGE
SOLID SILVER

BALLPOINT PEN / 891.281

Cartridge
Mechanism: Push button
Refills: Goliath cartridge, large, medium of fine (p. 144)



THE CASE
ECRIDOR GRAIN D'ORGE

184 x 80 x 40 mm
Standard screen-printed case
Includes:
- the user guide / guarantee
- a black Goliath M cartridge

Caran d'Ache has revised the Ecridor Grain d'Orge, in a tribute to the traditional craft of guilloché. Its body in solid silver, also called 925 silver, creates deep reflections, making it a truly high-quality writing instrument. The mark «Ag 925», stamped next to the clip, guarantees that the pen has been tested by a Swiss assay office and that the silver meets its strict criteria for fineness and purity.



ECRIDOR MATCH POINT



ECRIDOR MATCH POINT
PALLADIUM FINISH

BALLPOINT PEN / 890.515

Mechanism: Push button
Refills: Goliath cartridge, large, medium of fine (p. 144)



THE CASE
ECRIDOR MATCH POINT

184 x 80 x 40 mm
Standard screen-printed case
Includes:
- the user guide / guarantee
- a black Goliath M cartridge

With its hexagonal body, the iconic Ecridor model gives free rein to the artistic talent and extensive know-how of the master craftsmen at Caran d'Ache in terms of precision engraving. The Ecridor collection boasts a new creation, the Ecridor Match Point with its subtle references to the world of tennis. The new model pays homage to the ultimate winning shot during a game: the match point. Determining who wins, this crucial instant arouses a whole host of emotions and transcends the beauty of the sporting gesture of the final shot. The hexagonal body of the writing instrument is coated with palladium and meticulously polished. Fine laser engraving covers the pen, with a pattern recalling a tennis net. This delicate interlacing leaves a minute opening at the centre, just big enough for a ball to pass through from the other side of the court. In a final tip of the hat to the world of tennis, the end of the pen is decorated with an elegant tennis ball in relief.

With the new Ecridor Match Point model, Caran d'Ache pays homage to the talent of its ambassador, the young Swiss tennis player Belinda Bencic, wishing her many winning match points in her career.



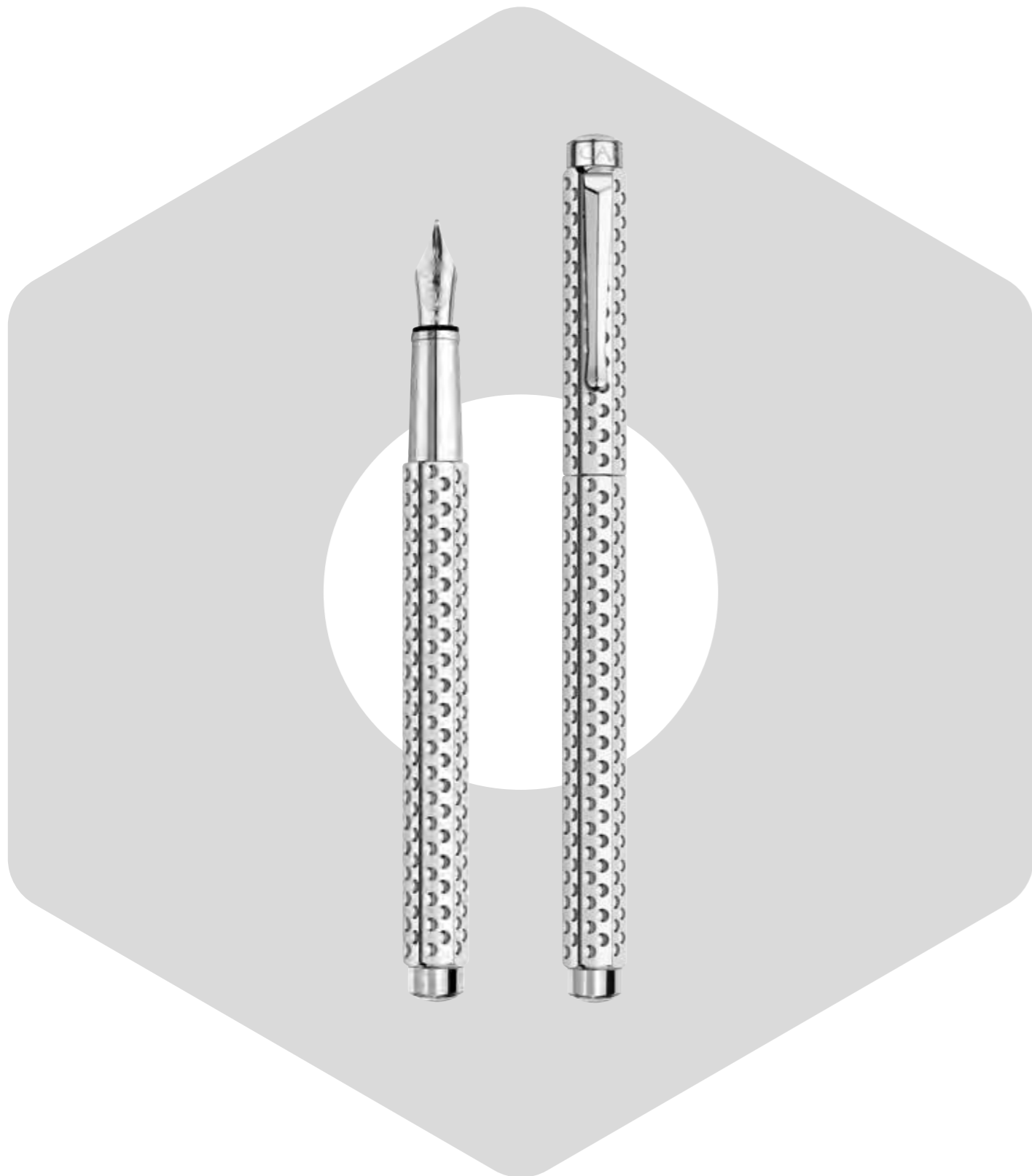

GOLF GUILLOCHE
 The Ecridor's unmistakable hexagonal body is decorated with an original geometric guilloché inspired by the dimples on a golf ball.



ECRIDOR GOLF
 PALLADIUM FINISH

FOUNTAIN PEN / M - 958.516

nib sizes: B-.526 / F-.506
 nib: steel, rhodium-coated
 Piston ink pump or ink cartridge
 Cap: Click-in
 Refill: Ink and cartridges Chromatics Collection (p.140 -143)



ECRIDOR GOLF
 PALLADIUM FINISH

ROLLER PEN / 838.516

Cartridge
 Cap: Click-in
 Refills: Roller cartridge, fine or medium, blue or black (p. 144)



ECRIDOR GOLF
 PALLADIUM FINISH

BALLPOINT PEN / 890.516 / CL890.526**

Cartridge
 Mechanism: Push button
 Refills: Goliath cartridge, large, medium or fine (p.144)



ECRIDOR GOLF
 PALLADIUM FINISH

MECHANICAL PENCIL / 4.516 / CL4.526**

0.7mm lead
 Mechanism: Push button
 Refills: 0.7 mm graphite leads, HB or B and replacement erasers (p.145)



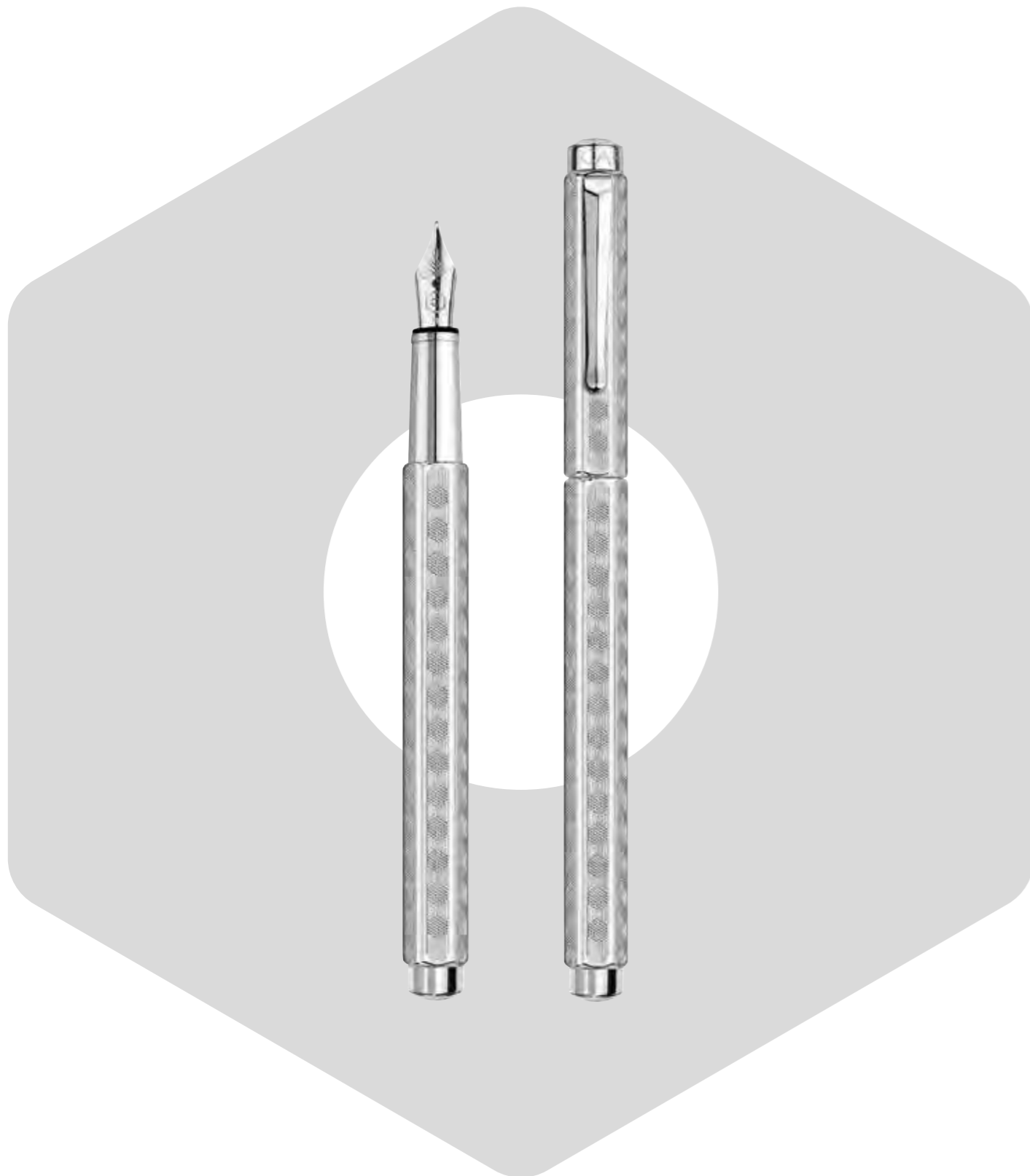

HERITAGE GUILLOCHE

The Ecridor Heritage is decorated with hexagons, a symbolic motif evoking the identity of the Geneva-based Maison. Like a kaleidoscope, the hexagon transforms into cubes revealing endless mirror perspective.



ECRIDOR HERITAGE
PALLADIUM FINISH

FOUNTAIN PEN / M-958.349

nib sizes: B -.359 / F -.339
nib: steel, rhodium-coated
Piston ink pump or ink cartridge
Cap: Click-in
Refill: Ink and cartridges Chromatics Collection (p.140 -143)



ECRIDOR HERITAGE
PALLADIUM FINISH

ROLLER PEN / 838.349

Cartridge
Cap: Click-in
Refills: Roller cartridge, fine or medium, blue or black (p. 144)



ECRIDOR HERITAGE
PALLADIUM FINISH

BALLPOINT PEN / 890.349 / CL 890.359**

Cartridge
Mechanism: Push button
Refills: Goliath cartridge, large, medium or fine (p.144)



ECRIDOR HERITAGE
PALLADIUM FINISH

MECHANICAL PENCIL / 4.349

0.7mm lead
Mechanism: Push button
Refills: 0.7 mm graphite leads, HB or B and replacement erasers (p.145)



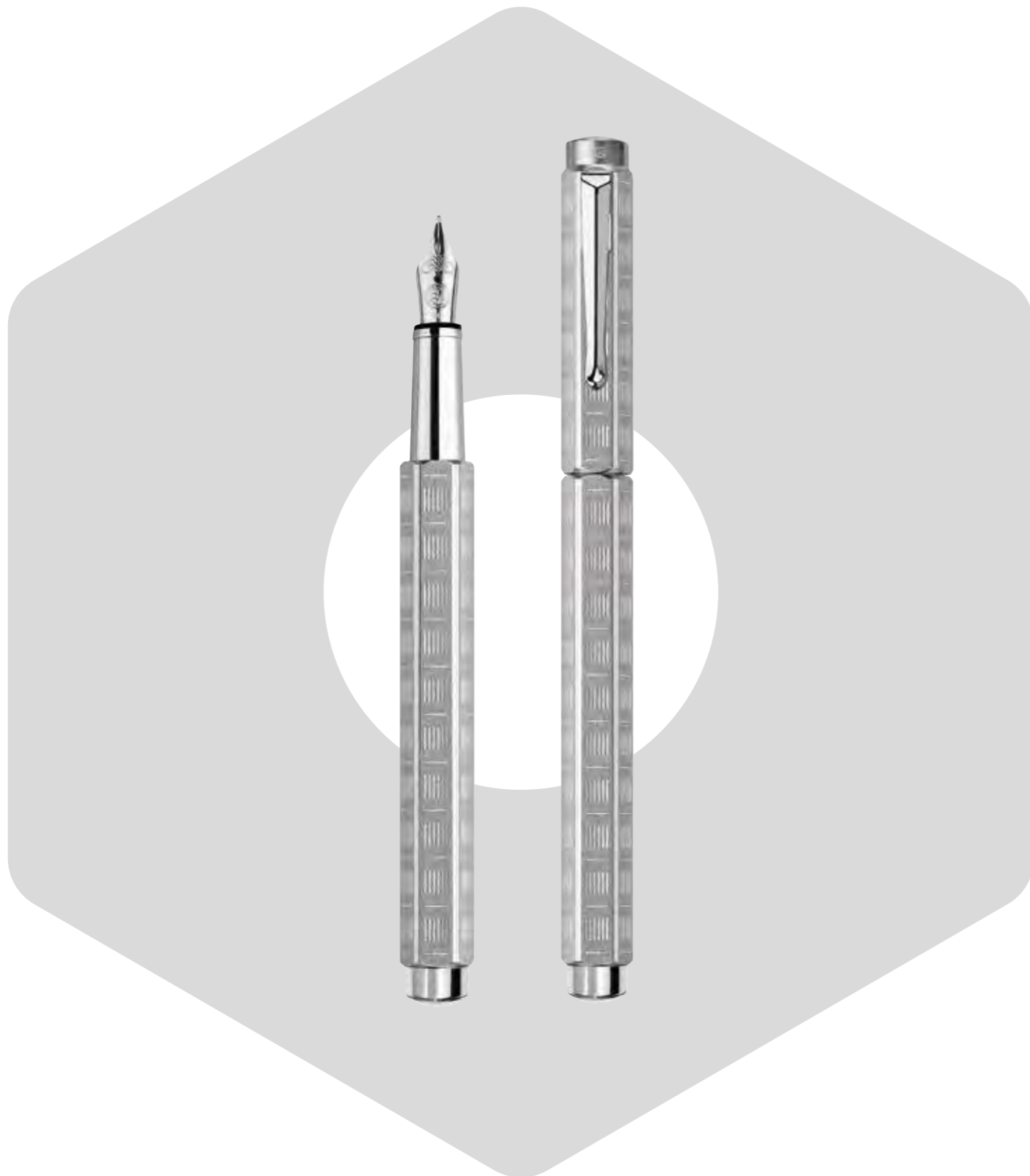

VARIATION GUILLOCHE

The six facets are decorated with guilloché geometric lines that reproduce endlessly to create a cascade of cubic shapes.



ECRIDOR VARIATION
PALLADIUM FINISH

FOUNTAIN PEN / M-958.347

nib sizes: B -.357 / F -.337
 nib: steel, rhodium-coated
 Piston ink pump or ink cartridge
 Cap: Click-in
 Refill: Ink and cartridges Chromatics Collection (p.140 -143)



ECRIDOR VARIATION
PALLADIUM FINISH

ROLLER PEN / 838.347

Cartridge
 Cap: Click-in
 Refills: Roller cartridge, fine or medium, blue or black (p. 144)



ECRIDOR VARIATION
PALLADIUM FINISH

BALLPOINT PEN / 890.347

Cartridge
 Mechanism: Push button
 Refills: Goliath cartridge, large, medium or fine (p.144)



ECRIDOR VARIATION
PALLADIUM FINISH

MECHANICAL PENCIL / 4.347

0.7mm lead
 Mechanism: Push button
 Refills: 0.7 mm graphite leads, HB or B and replacement erasers (p.145)



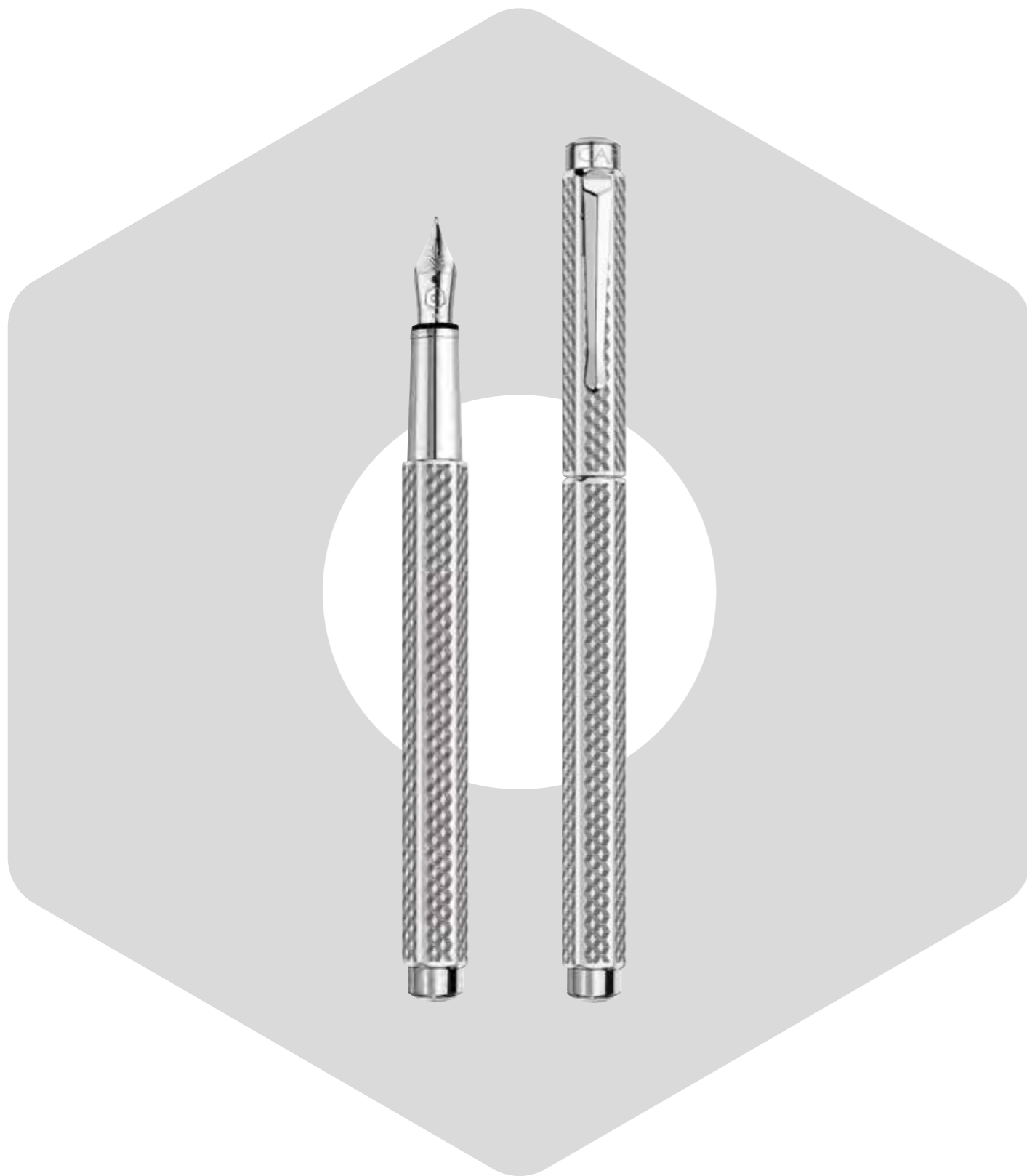

CUBRIK GUILLOCHE
 The six facets are decorated with guilloché geometric lines that reproduce endlessly to create a cascade of cubic shapes.

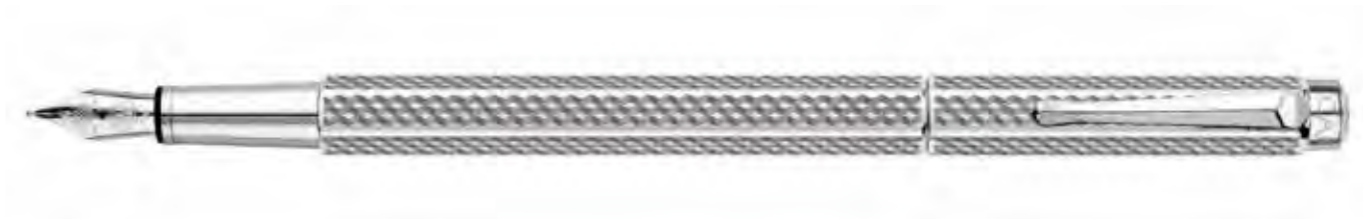

ECRIDOR CUBRIK
 PALLADIUM FINISH

FOUNTAIN PEN / M-958.377

nib sizes: B -.387 / F -.367
 nib: steel, rhodium-coated
 Piston ink pump or ink cartridge
 Cap: Click-in
 Refill: Ink and cartridges Chromatics Collection (p.140 -143)



ECRIDOR CUBRIK
 PALLADIUM FINISH

ROLLER PEN / 838.377

Cartridge
 Cap: Click-in
 Refills: Roller cartridge, fine or medium, blue or black (p. 144)



ECRIDOR CUBRIK
 PALLADIUM FINISH

BALLPOINT PEN / 890.377 / CL 890.387**

Cartridge
 Mechanism: Push button
 Refills: Goliath cartridge, large, medium or fine (p.144)

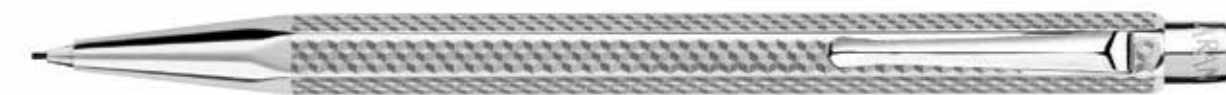

ECRIDOR CUBRIK
 PALLADIUM FINISH

MECHANICAL PENCIL / 4.377

0.7mm lead
 Mechanism: Push button
 Refills: 0.7 mm graphite leads, HB or B and replacement erasers (p.145)



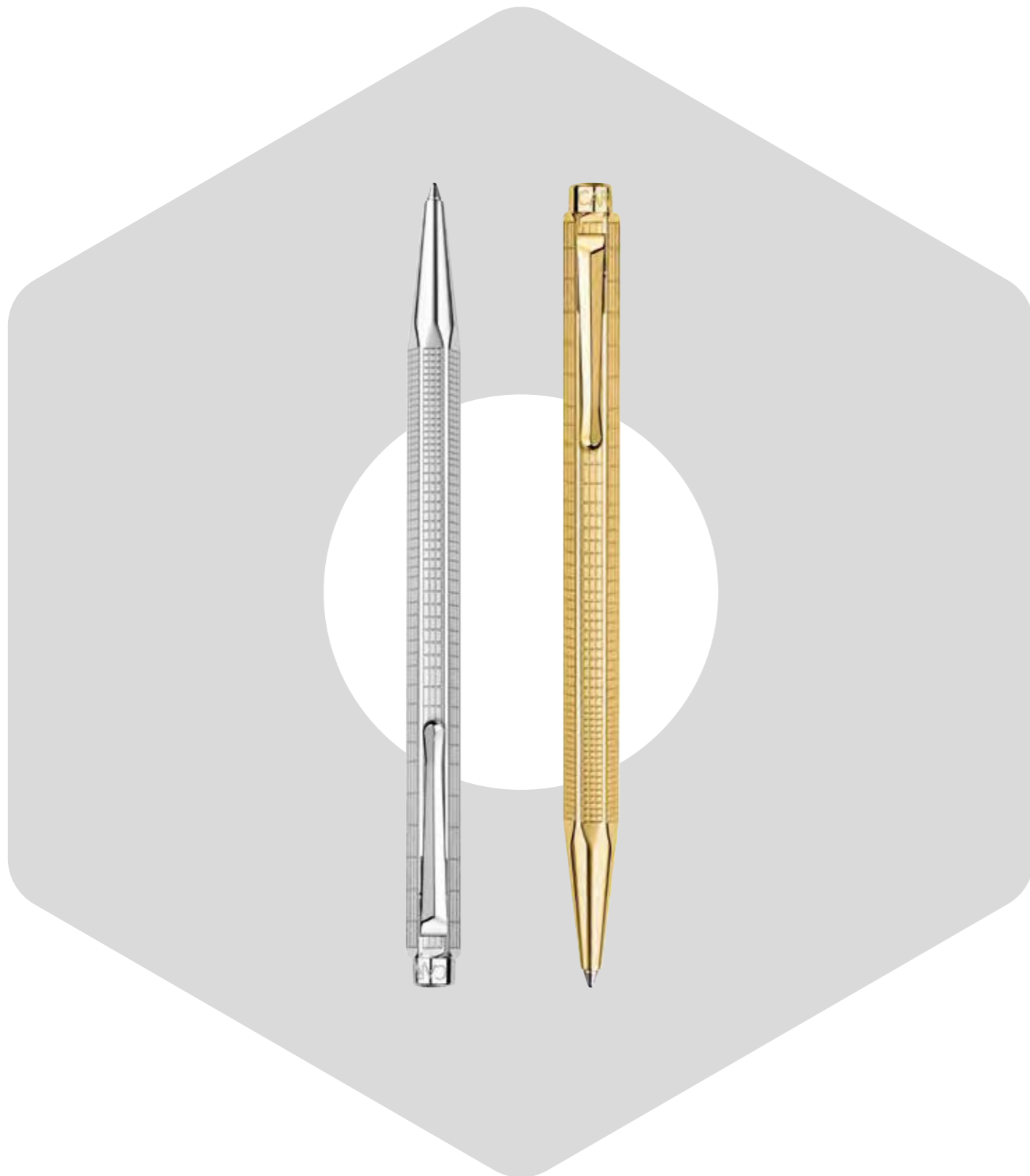

LIGNES URBAINES GUILLOCHE

For the Ecridor Lignes Urbaines, Caran d'Ache is inspired by the impressive, complicated and organised lines evoking world renowned skyscrapers.



ECRIDOR LIGNES URBAINES
PALLADIUM FINISH

BALLPOINT PEN / 890.366

Cartridge
Mechanism: Push button
Refills: Goliath cartridge, large, medium or fine (p.144)



ECRIDOR LIGNES URBAINES
PALLADIUM FINISH

MECHANICAL PENCIL / 4.366

0.7mm lead
Mechanism: Push button
Refills: 0.7 mm graphite leads, HB or B and replacement erasers (p.145)



ECRIDOR LIGNES URBAINES
GILDED FINISH

BALLPOINT PEN / 898.368

Cartridge
Mechanism: Push button
Refills: Goliath cartridge, large, medium or fine (p.144)



ECRIDOR LIGNES URBAINES
GILDED FINISH

MECHANICAL PENCIL / 4.368

0.7mm lead
Mechanism: Push button
Refills: 0.7 mm graphite leads, HB or B and replacement erasers (p.145)



ECRIDOR CHEVRON
GILDED FINISH

FOUNTAIN PEN / M-958.208

nib sizes: B - .218 / F - .198
nib: gilded steel
Piston ink pump or ink cartridge- Cap: Click-in
Refills: Ink and cartridges
Collection Chromatics (p.140 -143)

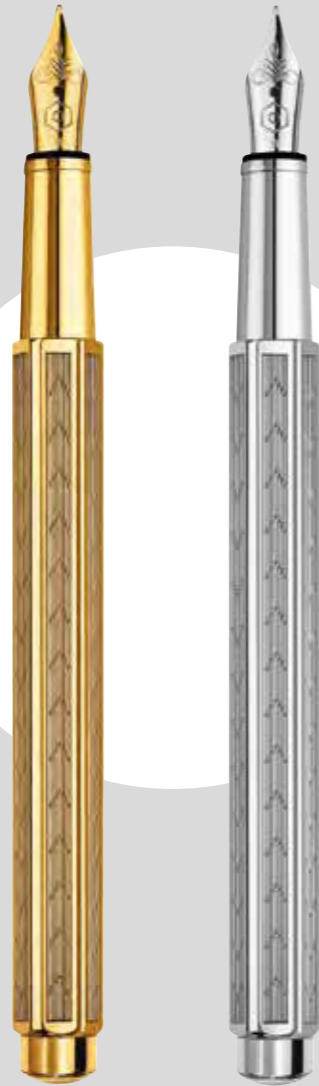

ECRIDOR CHEVRON
PALLADIUM FINISH

FOUNTAIN PEN / M-958.286 / CL** M-958.287

nib sizes: B - .296 / F - .276
CL: M-958.287 / B - .297 / F - .277
nib: steel, rhodium-coated
Piston ink pump or ink cartridge - Cap: Click-in
Refill: Ink and cartridges Chromatics Collection (p.140 -143)

CHEVRON GUILLOCHE

Inspired by a popular reversed v-shape design, the Chevron guilloche is engraved with the use of a diamond.



ECRIDOR CHEVRON
GILDED FINISH

ROLLER PEN / 838.208

Cartridge
Cap: Click-in
Refills: Roller cartridge, fine or medium, blue or black (p. 144)



ECRIDOR CHEVRON
GILDED FINISH

BALLPOINT PEN / 898.208 / CL** 898.408

Cartridge
Mechanism: Push button
Refills: Goliath cartridge, large, medium or fine (p.144)



ECRIDOR CHEVRON
GILDED FINISH

MECHANICAL PENCIL / 4.208 / CL** 4.408

0.7mm lead
Mechanism: Push button
Refills: 0.7 mm graphite leads, HB or B and replacement erasers (p.145)



ECRIDOR CHEVRON
PALLADIUM FINISH

ROLLER PEN / 838.286 / CL** 838.296

Cartridge
Cap: Click-in
Refills: Roller cartridge, fine or medium, blue or black (p. 144)



ECRIDOR CHEVRON
PALLADIUM FINISH

BALLPOINT PEN / 890.286 / CL** 890.296

Cartridge
Mechanism: Push button
Refills: Goliath cartridge, large, medium or fine (p.144)



ECRIDOR CHEVRON
PALLADIUM FINISH

MECHANICAL PENCIL / 4.286 / CL** 4.276

0.7mm lead
Mechanism: Push button
Refills: 0.7 mm graphite leads, HB or B and replacement erasers (p.145)



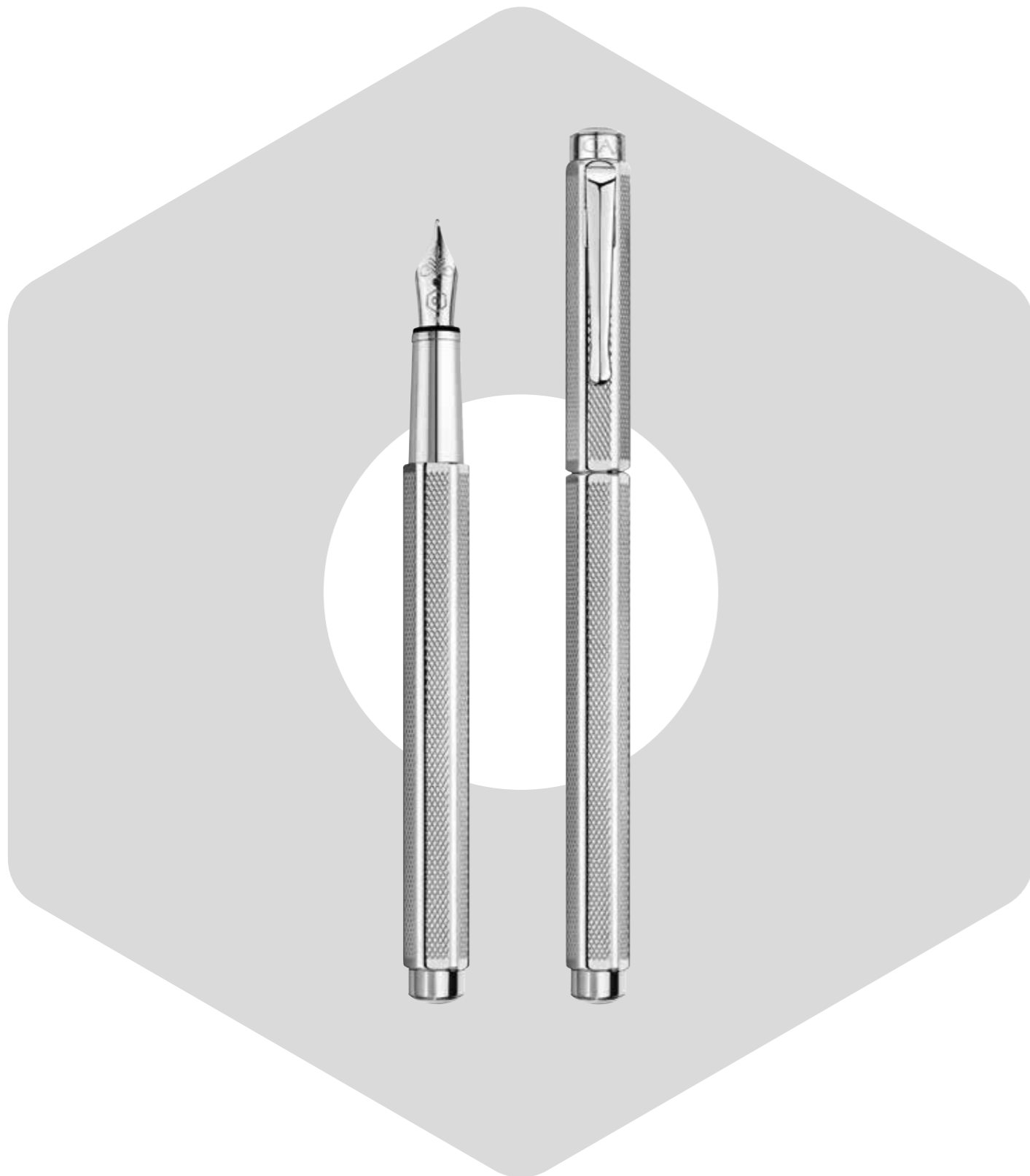

RETRO GUILLOCHE

Retro Guilloche is characterized by a lozenge decoration taken from the 1930s mechanical pencils, the first to be produced by the company with precious metals such as gold and silver.



ECRIDOR RETRO
PALLADIUM FINISH

FOUNTAIN PEN / M-958.485 / CL** 958.486

nib sizes: B -.495 / F -.475
Avec CL: M-958.486 / B -.496 / F -.476
nib: steel, rhodium-coated
Piston ink pump or ink cartridge
Cap: Click-in
Refill: Ink and cartridges Chromatics Collection (p.140 -143)



ECRIDOR RETRO
PALLADIUM FINISH

ROLLER PEN / 838.485 / CL** 838.495

Cartridge
Cap: Click-in
Refills: Roller cartridge, fine or medium, blue or black (p. 144)



ECRIDOR RETRO
PALLADIUM FINISH

BALLPOINT PEN / 890.487 / CL** 890.497

Cartridge
Mechanism: Push button
Refills: Goliath cartridge, large, medium or fine (p.144)



ECRIDOR RETRO
PALLADIUM FINISH

MECHANICAL PENCIL / 4.486 / CL** 4.496

0.7mm lead
Mechanism: Push button
Refills: 0.7 mm graphite leads, HB or B and replacement erasers (p.145)



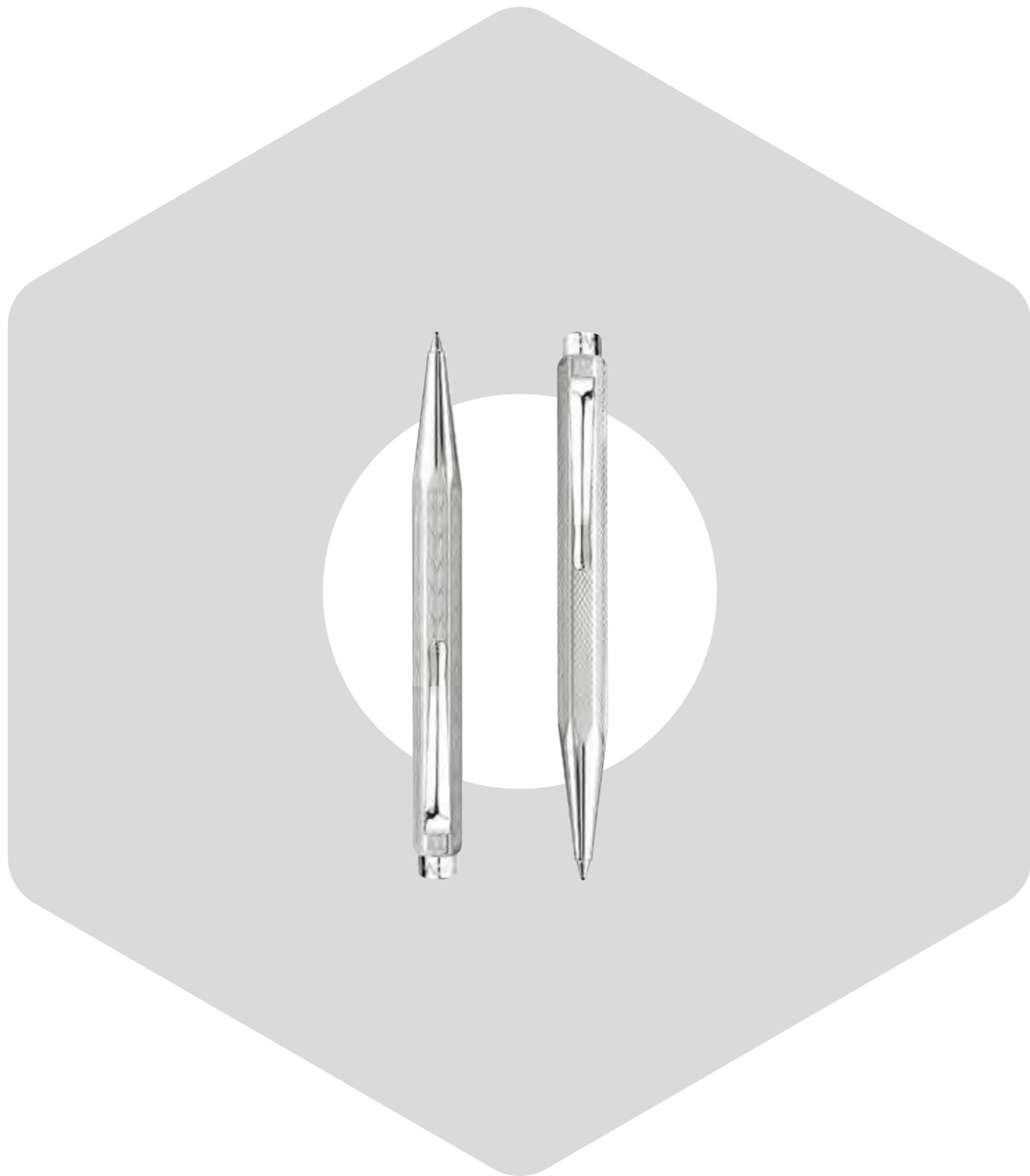

ECRIDOR XS CHEVRON
PALLADIUM FINISH

BALLPOINT PEN / 896.286

Cartridge
Mechanism: Push button
Refills: Ecridor XS cartridge (p. 144)



ECRIDOR XS CHEVRON
PALLADIUM FINISH

MECHANICAL PENCIL / 404.286

Mechanical pencil – 0.5 mm lead
Mechanism: Push button
Refills: Graphite leads 0.5 mm, HB or B and eraser (p. 145)



ECRIDOR XS RETRO
PALLADIUM FINISH

BALLPOINT PEN / 896.486

Cartridge
Mechanism: Push button
Refills: Ecridor XS cartridge (p. 144)



ECRIDOR XS RETRO
PALLADIUM FINISH

MECHANICAL PENCIL / 404.486

Mechanical pencil – 0.5 mm lead
Mechanism: Push button
Refills: Graphite leads 0.5 mm, HB or B and eraser (p. 145)



LIMITED EDITIONS ECRIDOR SET



The designers of the Geneva-based company have borrowed new graphic codes to create an exclusive writing set that is both elegant and in keeping with its time! With the Limited editions – ECRIDOR SET, Caran d'Ache has created a unique set combining exclusive items for writing, drawing and providing inspiration. The Ecridor ballpoint pen is engraved in HYGGE guilloché, inspired by the geometric patterns of Nordic textiles which make for cosy interiors and are associated with a genuine art of living. The two graphite pencils play on the elegance and sobriety of Scandinavian lines. By adding two inspiration notebooks to this exclusive gift set, Caran d'Ache offers people the chance to discover the accessories of the HAY brand, an emblem of contemporary Danish design.

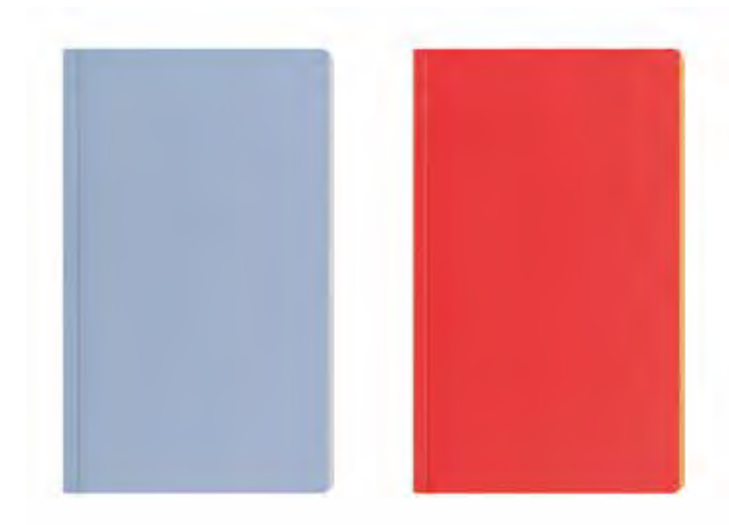
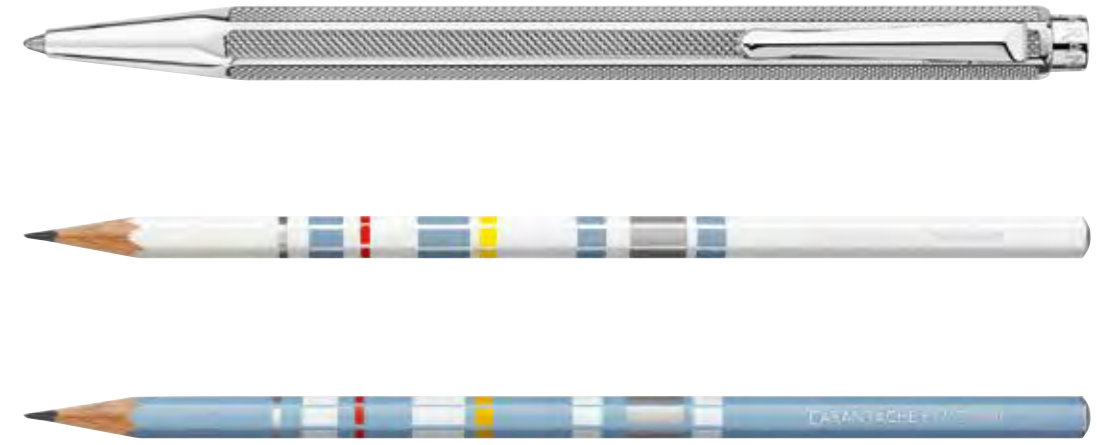

ECRIDOR GIFT SET
PALLADIUM FINISH
LIMITED EDITIONS

BALLPOINT PEN SET / CC0890.017

HYGGE Guilloché
Refills: Goliath cartridge, large, medium of fine (p. 144)
2 HB graphite pencils, blue and white
2 HAY "Edges" notebooks, blue and red





THE PENCILS OF LA MAISON CARAN D'ACHE

Caran d'Ache regularly introduces new noble materials to create original limited collections of pencils. These exclusive collections invite you to discover new countries through precious and exotic essences of noble woods, highlighting Caran d'Ache creativity in design and the art of writing.

- Certified FSC® (Forest Stewardship Council)
- Certified OLB (Origin and legality of the wood)
- Wood selected to meet strict quality criteria





THE PENCILS
OF CARAN D'ACHE
SCENTED EDITION

GRAPHITE PENCILS / 361.414

4 HB graphite pencils
Wood essences: Western Hemlock, White Oak, Silver Teak, White Ash
Perfume: Tibetan wood

For this new edition, Caran d'Ache is unveiling its scented pencils with «Tibetan wood perfume» revealing notes and essences of patchouli, incense and tonka bean. This unique scent will enchant both amateur and seasoned collectors of rare pencils.



THE PENCILS
OF CARAN D'ACHE
EDITION N°7

GRAPHITE PENCILS / 361.404

4 HB graphite pencils
Reconstituted wood species: polychrome sipo, streaked white birch, African assamela & grey limba

Always keen to find new, elegant materials, the craftsmen at Caran d'Ache create original and limited editions collections of pencils. These exclusive collections invite us to discover new lands. Polychrome sipo, streaked white birch, African assamela & grey limba ... all rare and precious woods, either unknown or revisited, from which Caran d'Ache has drawn inspiration to transcend its expertise in producing graphite leads.





WRITING ACCESSORIES



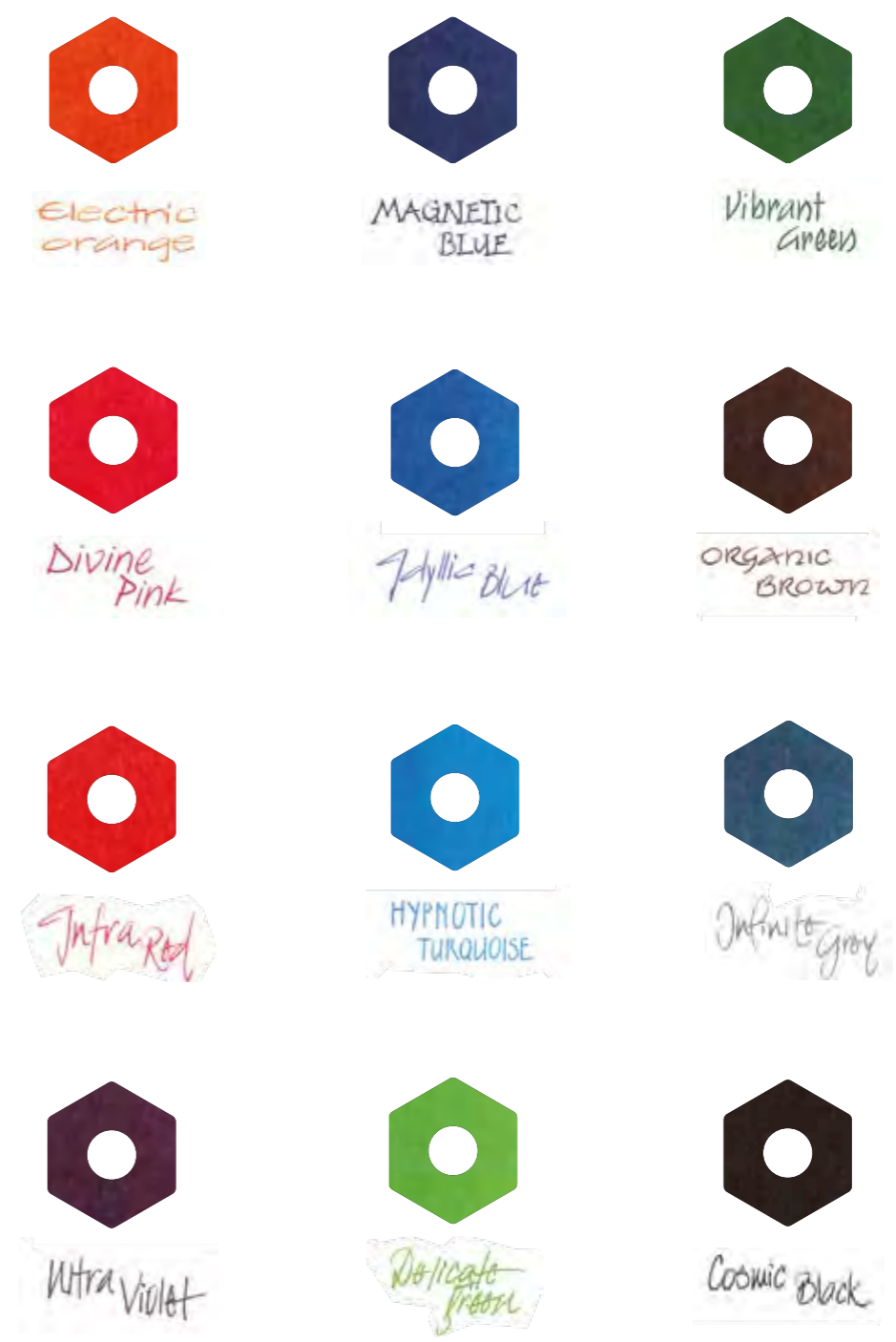

CHROMATICS

Within each new Caran d'Ache ink lies the expertise of a unique savoir-faire: the science of colours. Vibrant. Deep. Powerful. Sustained. From a bursting red to a radiant purple, from an empyreal turquoise to a fiery orange, Chromatics INKredible Colors impose their noble marks across the entire spectrum of light. Every inkwell is a prism, playing with the reflections of the light and intensifying the colour that it holds inside. Each personality submits to the caprices of evocative names that entice one inescapably away to voyage and discovery. Beyond their colours, the characters assert themselves through to the tip of the pen, and breathe life into the very page. The Art of Fine Penmanship is adorned in a colourful finery that vivifies the most beautiful pieces of written work.

12 colours / 50 ml ink bottle, with a hexagonal cap and inkwell / Ink bottle also available in sets of 6 or 12 colours / International ink cartridges (6 pieces per pack)





INK BOTTLE: ELECTRIC ORANGE / 8011.052



INK BOTTLE: DIVINE PINK / 8011.080



INK BOTTLE: HYPNOTIC TURQUOISE / 8011.191



INK BOTTLE: DELICATE GREEN / 8011.221



INK BOTTLE: INFRA RED / 8011.070



INK BOTTLE: ULTRA VIOLET / 8011.099



INK BOTTLE: VIBRANT GREEN / 8011.210



INK BOTTLE: ORGANIC BROWN / 8011.049



INK BOTTLE: IDYLIC BLUE / 8011.140



INK BOTTLE: MAGNETIC BLUE / 8011.149



INK BOTTLE: INFINITE GREY / 8011.005



INK BOTTLE: COSMIC BLACK / 8011.009

INK BOTTLE:
STARTER KIT

3 X 6 COLOURS / K18011.001

Bottle content: 50 ml
Included colours: Cosmic Black, Magnetic Blue, Electric Orange, Vibrant Green, Organic Brown, Hypnotic Turquoise

INK BOTTLE:
STARTER KIT

3 X 12 COLOURS / K18011.002

Bottle content: 50 ml
Included colours: Cosmic Black, Idyllic Blue, Magnetic Blue, Electric Orange, Vibrant Green, Organic Brown, Hypnotic Turquoise, Infra Red, Divine Pink, Delicate Green, Ultra Violet, Infinite Grey





INK CARTRIDGES ELECTRIC ORANGE / 8021.052



INK CARTRIDGES DIVINE PINK / 8021.080



INK CARTRIDGES HYPNOTIC TURQUOISE / 8021.191



INK CARTRIDGES DELICATE GREEN / 8021.221



INK CARTRIDGES INFRA RED / 8021.070



INK CARTRIDGES ULTRA VIOLET / 8021.099



INK CARTRIDGES VIBRANT GREEN / 8021.210



INK CARTRIDGES ORGANIC BROWN / 8021.049



INK CARTRIDGES IDYLIC BLUE / 8021.140



INK CARTRIDGES MAGNETIC BLUE / 8021.149



INK CARTRIDGES INFINITE GREY / 8021.005



INK CARTRIDGES COSMIC BLACK / 8021.009





CARTRIDGES
BALLPOINT PEN

GOLIATH CARTRIDGE

Large 8422.260 (Blue) / 8428.109 (Black)
Medium 8422.000 (Blue) / 8428.000 (Black) / 8420.000 (Red) / 8418.000 (Green)
Fine 8422.160 (Blue) / 8428.009 (Black) / 8420.070 (Red)



CARTRIDGES
ROLLER

FIBRE CARTRIDGE / Medium

8122.000 (Blue) / 8128.000 (Black)



CARTRIDGES
ROLLER

FIBRE CARTRIDGE / Fine

8122.160 (Blue) / 8128.009 (Black)



CARTRIDGES
ROLLER

CARTRIDGE / Fine

8222.160 (Blue) / 8228.009 (Black)

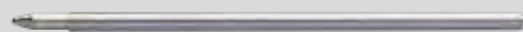

CARTRIDGES
BALLPOINT PEN

ECRIDOR XS CARTRIDGE

6522.100 (Blue) / 6528.100 (Black)



CARTRIDGES
BALLPOINT PEN

RNX.316 MULTIFUNCTION CARTRIDGES

6533.105
Batch quantity: 5 cartridges
Colours: 2 Blue, 2 Blacks, 1 Red



ERASERS

505.000 Madison, Ecridor, RNX.316
506.000 Léman
512.000 Léman Slim
507.000 Varius, Ecridor XS



BLACK ERASER

180.000



REFILLS
GRAPHITE LEADS

GRAPHITE LEADS 0.5 MM / 12-piece pack

6705.350 60mm HB
6705.351 60mm B

GRAPHITE LEADS 0.7 MM / 12-piece pack

6707.350 60mm HB
6707.351 60mm B

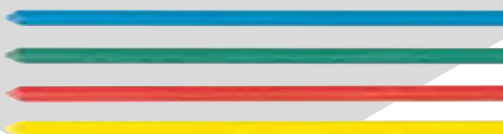

REFILLS
COLOUR LEADS

ARTIST COLOUR LEADS 2 MM FOR RNX.316

Pack size: 4 leads
6077.786
Colours: Blue, Green, Red and Yellow





ACCESSORIES





HAUTE MAROQUINERIE

Caran d'Ache wished to create a collection that would match the priceless expertise it has in the art of fine writing. The subtle play of colours, the silky feel of the interior finishing in nubuck leather, the quality of the calfskin... This is a captivating collection that awakens each of the senses. Like certain jewels, Caran d'Ache writing instruments seem to have a special softness. Pen holder, wallet, card holder, diary and document case becomes articles of ultimate refinement, arousing emotions...

Calfskin leather / Nubuck interiors / Saddle stitching / Depth and intensity of shades / Palladium-coated metal parts / One-year international guarantee from the date of purchase / Manufactured in Europe



HAUTE MAROQUINERIE
CALFSKIN LEATHER BLACK

HOLDER FOR 1 PEN / 6201.009
Dimensions: 3 x 15 cm



HAUTE MAROQUINERIE
CALFSKIN LEATHER BLACK

HOLDER FOR 2 PENS / 6202.009
Dimensions: 4 x 15 cm



HAUTE MAROQUINERIE
CALFSKIN LEATHER BLACK

HOLDER FOR 3 PENS / 6203.009
Dimensions: 5 x 15 cm



HAUTE MAROQUINERIE
CALFSKIN LEATHER BLACK

HOLDER FOR 4 PENS / 6204.009
Dimensions: 6 x 15 cm



HAUTE MAROQUINERIE
CALFSKIN LEATHER BLACK

FOLDED PURSE / 6205.009

Dimensions: 8 x 6.5 cm



HAUTE MAROQUINERIE
CALFSKIN LEATHER BLACK

MULTI CREDIT CARD CASE / 6231.009

Dimensions: 10 x 6.2 cm

- HAUTE MAROQUINERIE

HAUTE MAROQUINERIE
CALFSKIN LEATHER BLACK

4-CARD WALLET WITH COIN CASE / 6208.009

Dimensions: 11 x 9 cm



HAUTE MAROQUINERIE
CALFSKIN LEATHER BLACK

BUSINESS CARD HOLDER / 6207.009

Dimensions: 8 x 11 cm

HAUTE MAROQUINERIE
CALFSKIN LEATHER BLACK

SMALL MEMO / 6206.009

Dimensions: 11 x 9 cm
Refill: 5506.070



HAUTE MAROQUINERIE
CALFSKIN LEATHER BLACK

KEY RING / 6239.009





HAUTE MAROQUINERIE
CALFSKIN LEATHER BLACK

POCKET ORGANIZER / 6237.009

Dimensions: 15 x 9 cm
Refill: 5537.070



HAUTE MAROQUINERIE
CALFSKIN LEATHER BLACK

PASSPORT HOLDER WITH ZIP / 6211.009

Dimensions: 22 x 12 cm



HAUTE MAROQUINERIE
CALFSKIN LEATHER BLACK

PASSEPORT HOLDER / 6212.009

Dimensions: 13.5 x 9.5 cm



HAUTE MAROQUINERIE
CALFSKIN LEATHER EBONY

POCKET ORGANIZER / 6237.059

Dimensions: 15 x 9 cm
Refill: 5537.070



HAUTE MAROQUINERIE
CALFSKIN LEATHER EBONY

PASSPORT HOLDER WITH ZIP / 6211.059

Dimensions: 22 x 12 cm



HAUTE MAROQUINERIE
CALFSKIN LEATHER EBONY

PASSEPORT HOLDER / 6212.059

Dimensions: 13.5 x 9.5 cm



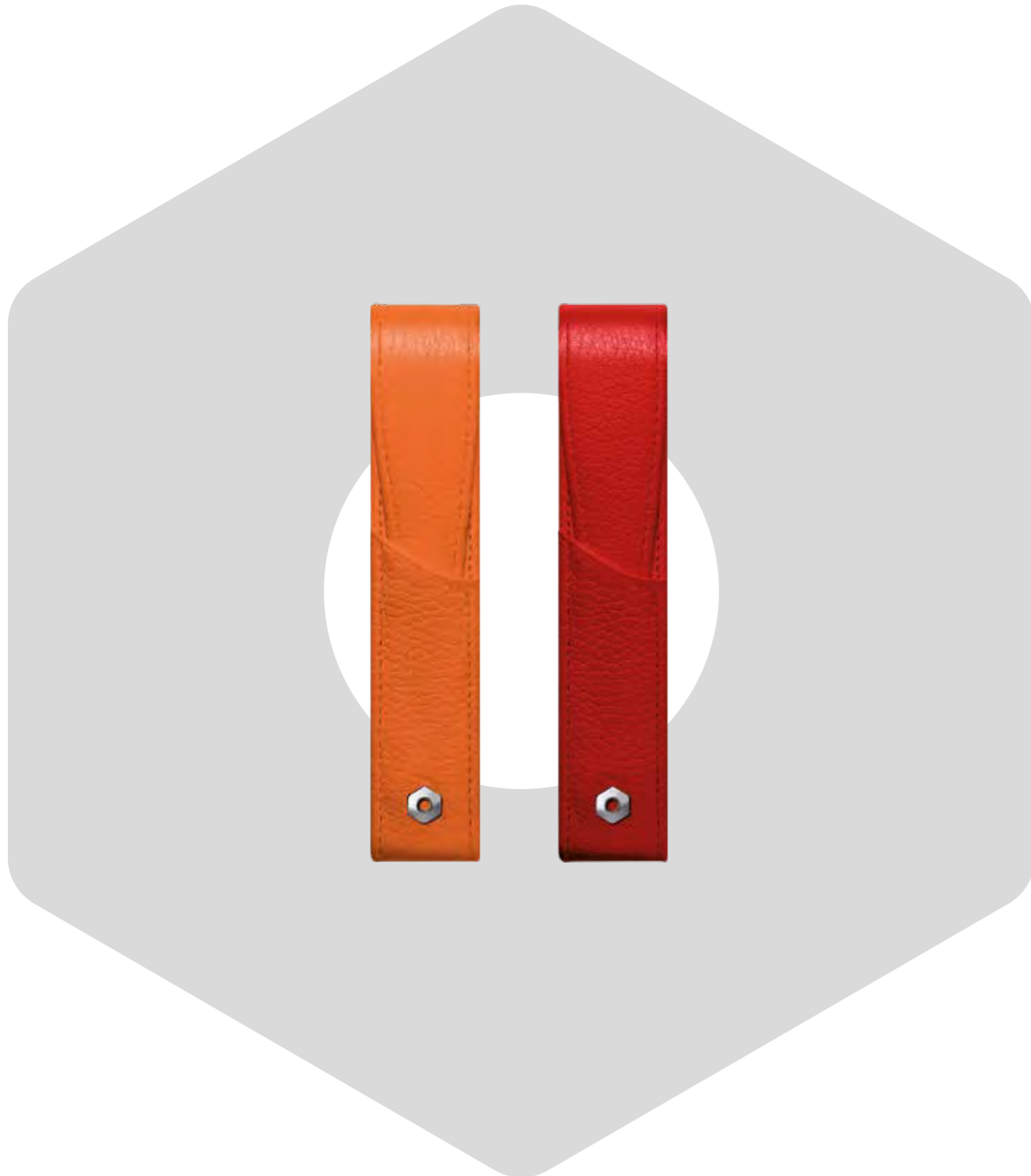

LÉMAN

Vivid leather colours, deep intense shades... A fresh wind blows on Caran d'Ache accessories with this line of small leatherware that matches the writing instruments. Pen cases, card holders, and wallets in grained calfskin reject all trace of austerity. In a rainbow of colours, the Léman range gives the leather a contemporary feel, full of charm and joyful elegance.

Grained calfskin leather / Saddle stitching / Jacquard lining / Palladium-coated metal parts / One-year international guarantee from the date of purchase / Manufactured in Europe



LÉMAN BLACK
GRAINED CALFSKIN LEATHER

HOLDER FOR 1 PEN / 6201.782

Dimensions: 2.5 x 15 cm



LÉMAN WHITE
GRAINED CALFSKIN LEATHER

HOLDER FOR 1 PEN / 6201.001

Dimensions: 2.5 x 15 cm



LÉMAN SAFRAN
GRAINED CALFSKIN LEATHER

HOLDER FOR 1 PEN / 6201.530

Dimensions: 2.5 x 15 cm



LÉMAN TURQUOISE
GRAINED CALFSKIN LEATHER

HOLDER FOR 1 PEN / 6201.171

Dimensions: 2.5 x 15 cm



LÉMAN RED
GRAINED CALFSKIN LEATHER

HOLDER FOR 1 PEN / 6201.770

Dimensions: 2.5 x 15 cm



LÉMAN BLUE
GRAINED CALFSKIN LEATHER

HOLDER FOR 1 PEN / 6201.449

Dimensions: 2.5 x 15 cm





LÉMAN BLACK
GRAINED CALFSKIN LEATHER

HOLDER FOR 2 PENS / 6202.782

Dimensions: 4 x 15 cm



LÉMAN WHITE
GRAINED CALFSKIN LEATHER

HOLDER FOR 2 PENS / 6202.001

Dimensions: 4 x 15 cm



LÉMAN SAFRAN
GRAINED CALFSKIN LEATHER

HOLDER FOR 2 PENS / 6202.530

Dimensions: 4 x 15 cm



LÉMAN TURQUOISE
GRAINED CALFSKIN LEATHER

HOLDER FOR 2 PENS / 6202.171

Dimensions: 4 x 15 cm



LÉMAN RED
GRAINED CALFSKIN LEATHER

HOLDER FOR 2 PENS / 6202.770

Dimensions: 4 x 15 cm



LÉMAN BLUE
GRAINED CALFSKIN LEATHER

HOLDER FOR 2 PENS / 6202.449

Dimensions: 4 x 15 cm





LÉMAN WHITE
GRAINED CALFSKIN LEATHER

BUSINESS CARD HOLDER / 6207.001
Dimensions: 10,5 x 8 cm



LÉMAN GREY
GRAINED CALFSKIN LEATHER

BUSINESS CARD HOLDER / 6207.007
Dimensions: 10,5 x 8 cm

LÉMAN CASHMERE
GRAINED CALFSKIN LEATHER

BUSINESS CARD HOLDER / 6207.403
Dimensions: 10,5 x 8 cm



LÉMAN SAFFRON
GRAINED CALFSKIN LEATHER

BUSINESS CARD HOLDER / 6207.530
Dimensions: 10,5 x 8 cm



KEY RING WHITE / 6239.001
Material: grained calfskin leather



KEY RING GREY / 6239.007
Material: grained calfskin leather



KEY RING CASHMERE / 6239.403
Material: grained calfskin leather



KEY RING SAFFRON / 6239.530
Material: grained calfskin leather





LÉMAN WHITE
GRAINED CALFSKIN LEATHER

WOMAN'S WALLET / 6214.001
Dimensions: 19 x 10.5 cm



LÉMAN GREY
GRAINED CALFSKIN LEATHER

WOMAN'S WALLET / 6214.007
Dimensions: 19 x 10.5 cm



LÉMAN CASHMERE
GRAINED CALFSKIN LEATHER

WOMAN'S WALLET / 6214.403
Dimensions: 19 x 10.5 cm



LÉMAN SAFFRON
GRAINED CALFSKIN LEATHER

WOMAN'S WALLET / 6214.530
Dimensions: 19 x 10.5 cm



LÉMAN RED
GRAINED CALFSKIN LEATHER

WOMAN'S WALLET / 6214.770
Dimensions: 19 x 10.5 cm



LÉMAN TURQUOISE
GRAINED CALFSKIN LEATHER

WOMAN'S WALLET / 6214.171
Dimensions: 19 x 10.5 cm





A5 BOOK SAFFRON / 6233.530
 Material: grained calfskin leather
 Dimensions: 22x17.5 cm
 Refill: 5533.073



A5 BOOK WHITE / 6233.001
 Material: grained calfskin leather
 Dimensions: 22x17.5 cm
 Refill: 5533.073



A5 BOOK GREY / 6233.007
 Material: grained calfskin leather
 Dimensions: 22x17.5 cm
 Refill: 5533.073



A5 BOOK CASHMERE / 6233.403
 Material: grained calfskin leather
 Dimensions: 22x17.5 cm
 Refill: 5533.073



A5 BOOK BLACK / 6233.782
 Material: grained calfskin leather
 Dimensions: 22x17.5 cm
 Refill: 5533.073



A5 BOOK BLUE / 6233.449
 Material: grained calfskin leather
 Dimensions: 22x17.5 cm
 Refill: 5533.073



A5 BOOK TURQUOISE / 6233.171
 Material: grained calfskin leather
 Dimensions: 22x17.5 cm
 Refill: 5533.073



A5 BOOK RED / 6233.770
 Material: grained calfskin leather
 Dimensions: 22x17.5 cm
 Refill: 5533.073





BELTS CLASSIC
RECTANGULAR BUCKLE

CLASSIC REVERSIBLE BLACK / BROWN / 5205.009
Dimensions: 3 x 120 cm
Buckle: palladium-plated rectangular pin
Leather: reversible black / brown



BELTS CLASSIC
ROUND BUCKLE

CLASSIC REVERSIBLE BLACK / BROWN / 5206.009
Dimensions: 3 x 120 cm
Buckle: palladium-plated round pin
Leather: reversible black / brown

BELTS
In matters of elegance, the little details can make all the difference. Caran d'Ache appeals to seriously elegant men with a collection of reversible belts for a contemporary look. The Maison has used all its expertise to develop these top-of-the-range accessories that are made from the finest leathers and fitted with metal buckles coated in palladium.

Reversible colour belts / Length adjustable by strap cutting process / Buckle in strap-cutting, palladium-plated brass / One-year international guarantee from the date of purchase / Manufactured in Italy





CUFFLINKS IVANHOE / 5350.014

Body sheathed in coat of mail
Matériau: acier inoxydable



CUFFLINKS TYPE 55 / 5350.455

Material: stainless steel



CUFFLINKS ALLIGATOR / 5350.021

Body covered in chocolate brown alligator skin
Material: stainless steel



CUFFLINKS CUBRIK / 5350.377

Material: stainless steel



CUFFLINKS SNAKEWOOD / 5350.023

Snakewood body
Material: stainless steel



CUFFLINKS RETRO / 5350.485

Material: stainless steel

CUFFLINKS

Much admired by discerning clients, the Maison Caran d'Ache declares its intentions by emphasizing this accessory which is not simply a piece of jewellery but a genuine fashion accessory. The perfect harmony between writing instruments and cufflinks is an expression of ultimate refinement where no details has been left to chance. Choosing a Caran d'Ache writing instrument means choosing the signature of style and prestige. Precious and visually striking, these fashion accessories are an extension of each collection of writing instruments, imbued with the same character and originality.

Stainless steel / One-year international guarantee from the date of purchase

VARIUS

Based on the design of the Varius collection, the iconic line of the brand, the Geneva craftsmen have expanded their expertise in working with noble materials and have developed superb variations around the coat of mail, snakewood and alligator leather.

ECRIDOR

The Ecridor collection explores the infinite possibilities of the famous hexagon with highly successful adaptations of the Type 55, Cubrik and Retro lines. The body of each model, produced in stainless steel, carries the Caran d'Ache signature engraved on the mechanism.





SERVICES



FOUNTAIN PEN NIBS

The most authentic form of writing, showing every variation in pressure and speed, is that of the fountain pen. A pen moulds itself to its user's writing, which is why Caran d'Ache offers a range of widths for its hand-made and hand-polished nibs offering their owners exquisite writing comfort.



- Steel rhodium nib or steel nib coated in black PDV
- Nibs made from 18-carat gold, rhodium-plated 18-carat gold or 18 carat pink gold-plating
- For the Ecridor, the nibs are made from rhodium- or silver-plated stainless steel
- Available in 4 tip sizes: F, M, B, BB
- Sizes available for the Varius collection: EF, F, M, B, OM, OB, BB
- Unparalleled writing comfort recognised worldwide

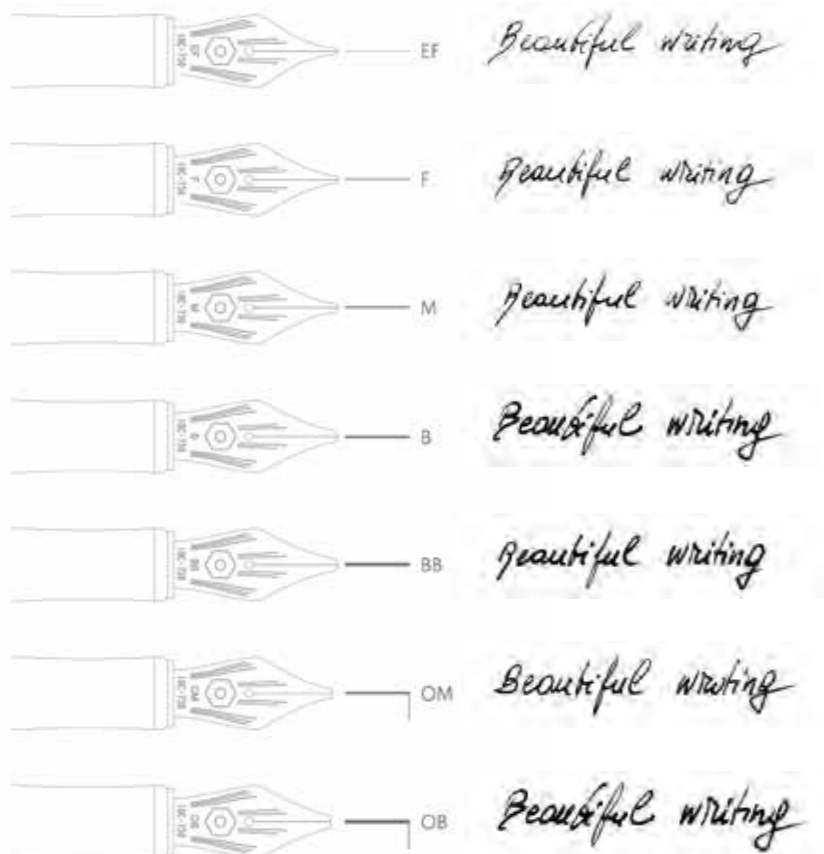

PERSONALISED ENGRAVING

Numerous Caran d'Ache writing instruments can be engraved on request to the brand retailers. On the side opposite the clip, the company's craftsmen have taken care to leave a space intended for personalised engraving.

This is where the customer can give free rein to his or her imagination.

A name, a date or a short message... the writing instrument becomes a highly personal object, unlike any other.



Helvetica



Script Filaire



Book Antiqua

«OTHER TYPEFACES ARE AVAILABLE ON REQUEST. THE CHOICE OF TYPEFACE AND THE NUMBER OF CHARACTERS MAY VARY DEPENDING ON THE COLLECTION.»

INTERNATIONAL GUARANTEE

Lovers of handwriting often develop a real attachment to their pens. For this reason, our after-sales technicians do their very best to repair them whenever possible, only replacing them as a last resort. Repairs under guarantee are free of charge and other repairs are only carried out after the client has accepted a cost estimate.

Caran d'Ache writing instruments are inspected and tested at each stage of production. When they leave the Geneva workshops they are in perfect condition and are guaranteed against any manufacturing defects. An international guarantee certificate accompanies each instrument.

HOW TO FILL IN THE GUARANTEE CERTIFICATE ?

- Product: product reference
- Date of purchase: month / year
- Finishing: gold, silver, gold-plated, silver-plated, palladium-coated, platinum-coated etc.
- Dealer's stamp: from the retailer



CORPORATE GIFTS

The name itself represents a prestigious, educational world and is now a synonym for excellence and creativity. More than simply a brand, the Swiss company has imposed its own style: a "Maison de Haute Ecriture".

With more than 200 writing instruments for both top-of-the-range luxury market and for the office, Caran d'Ache can propose many personalised gifts which are sure to capture attention. If you wish to thank your clients and keep their loyalty, or invigorate your sales team, have a look through our special catalogue and ask us for a quotation.

PACKAGING

To meet the needs of our partners and their customers, Caran d'Ache provides easily identifiable packaging for each of our writing instruments with a consistent choice of colours, optimal sizes, designs and top-of-the-range materials. Black cases highlighted with Caran d'Ache logo in hot silver makes a high-quality presentation for all writing instruments reinforcing the brand image carefully preserved over several generations.

- Red shopping bags with black handles (available in 3 sizes)
- Gift pouches with adhesive closure (available in 3 sizes)
- Red or white satin ribbon with embossed logo
- Reversible red and black wrapping paper with logo



THE MERCHANDISING AT CARAN D'ACHE

MERCHANDISING

Merchandising refers to all the methods and techniques of implementing and showcasing products in boutiques, making it possible to increase a brand's visibility at the points of sale.

Unique and consistent merchandising makes a brand easy to recognise and gives it a strong identity that is the same anywhere in the world.

MERCHANDISING AT CARAN D'ACHE

Our new merchandising concept for writing instruments reflects a recent realisation by the company: the opportunity to present all our products and ranges in the same place and with the same identity.

To mark its centenary in 2015, Caran d'Ache unveiled a new, single logo for all its products. This logo, (while drawing on the history of the brand) is clear, sober and modern, offering new visibility. It is sometimes also accompanied by the hexagonal isotype, directly inspired by the iconic pencils by Caran d'Ache.

It is against this backdrop, and with a desire to juxtapose our three worlds in a coherent manner, that the global retail concept has been defined. The Haute Ecriture concept is thus the fruit of this new juxtaposition and adapts to the new codes and new identification. It, too, is clear and modern.

THE MERCHANDISING CATALOGUE

The aim of this document is to incorporate all the tools and guidelines in order to ensure optimum presentation of our writing range in our corners, our furniture or in any presentation space.

- Brochure available in 5 languages as a PDF file
- 51 inside pages



CARAN^D'ACHE

Genève

CARAN d'ACHE S.A. – Chemin du Foron, 19 – CH-1226 Thônex-Genève

Tel. +41 (0) 22 869 01 01 – Fax +41 (0) 22 869 01 39

ECRIDOR SAS · 5, Place Porte de France · F-74240 Gaillard

carandache.com